



60163 TORNADO
New Steam for the Main Line



2007 PRINCE OF WALES
Building Britain's Most Powerful Steam Locomotive



3403 HIGHLANDER
Recreating Gresley's last design

THE COMMUNICATION CORD

No. 72 Spring/Summer 2024



The first half of 2024 has seen significant progress in the P2 project. Following the success of 'The Valve Gear Club', launched in spring and catalysing further activity this summer, the project reached another milestone in June as we received the tender frames at DLW. Fundraising for the tender continues in order to enable full construction. More details within this edition of TCC.

CONTENTS

PAGE 1
Arrival of P2's tender frames at DLW

PAGE 2
Contents
Editorial

PAGE 3
From the Chair
AI Fundraising

PAGE 4
Profile - David Elliott

PAGE 6
AI overhaul

PAGE 11
ETCS update

PAGE 15
Jordan Hejaz Railway visits AISLT

PAGE 16
Tributes to David Elliott

PAGE 21
AI shop - New Arrivals

PAGE 22
The big picture

PAGE 24
Railtours
Legacy giving

PAGE 25
Get on board with Tornado

PAGE 26
AI profile - No. 60143 Sir Walter Scott

PAGE 28
Covenantors' Diary

PAGE 29
Armed Forces Covenant

PAGE 30
Tender Frames delivered to Darlington
Ian Howitt

PAGE 31
Volunteers

PAGE 32
P2 Fundraising

PAGE 34
P2 progress
Club Badges

PAGE 35
Valve gear reached first milestone
Convention 2024 - Save the date

PAGE 36
90th Anniversary of the Gresley P2 Class

PAGE 39
P2 Dedicated Donations update
Workshop notes

PAGE 40
Army on track at DLW

PAGE 41
Prime Minister Rishi Sunak visits DLW

PAGE 42
The P-Way Gang - phase two

PAGE 43
Volunteers on point at DLW

PAGE 44
From the archives

Sponsors and contact information

EDITORIAL by Graham Langer



As Editor of *TCC*, I must apologise for the lateness of this edition of *TCC*. We held off publication in the hope we could report *Tornado* in steam, signalling the end of the overhaul however there have been more challenges to overcome in that area than anticipated, thus delaying this issue. As such we now have a bumper edition for you, covering all Trust activity this year, including significant advances in the P2 project and around the new Darlington Locomotive Works site.

Just before Christmas we heard the dreadful but not unexpected news that David Elliott had passed away. A full tribute to him appears on page four but I would like to add a few personal words of my own. It is more than evident that David was a skilled engineer and an original thinker and his dedication and loyalty to the Trust was total, working until he was no longer able to ensure that he had "brain dumped" as much of his knowledge on Alan Parkin and others who needed to know. The overwhelming theme expressed in the tributes paid to him in this edition of *TCC* is recognition of what a genuinely lovely person he was and many refer to the kindness he showed to others. For my own part, I will long value the time David was willing to spend educating a comparative tyro such as myself in the darker arts of steam locomotive construction. We will all miss him.

David Elliott's legacy will, however, live on, in two outstanding 21st century steam locomotives and the new works in Hopetown. The new Darlington heritage quarter opened in July and our building has already been connected to North Road station by a dedicated footbridge, indeed the next months are going to see fast and furious progress on numerous fronts as assorted strands of Trust activity start to be pulled together. The P2 saw a significant milestone reached in June with the delivery of the tender frames, and August will see progress begin on the Valve Gear.

By the time of the Convention in the autumn a substantial amount of track will have been laid to connect the works with the main line and the Whessoe Road engine shed, essential if we are to be able to use DLW as a servicing base for *Tornado* (and other steam locomotives) when they are operating in the area. Your support of the PW Gang has been fundamental in maintaining progress in this area, let's hope that some of the seeds sown during a recent ministerial visit will result in the funding for a turntable, an essential ingredient in making Darlington a destination for railtours, rather than just a passing place.

TCC



David Elliott stands proudly in front of *Tornado* when the locomotive was first steamed at Darlington Locomotive Works in 2008

Ken Richardson

FROM THE CHAIR by Steve Davies



You will have already read in the Editorial of yet further delays to the steaming of No. 60163, and we had hoped that the front cover of this edition would be able to carry a photograph of this long awaited event, but alas, that has not been possible. We can only apologize for the delay to this edition (especially for those who are unable to be kept updated electronically)

but just recently we have had to contend with problems with the air braking system which contractors had to redesign to match the needs of European Train Control System (ETCS). It's been a long old haul – and it's not over yet! With testing, of both the locomotive and the ETCS now about to start, it has been well worth the wait. The overhaul has been far from straightforward, with complexity and the unexpected jointly – and frequently - conspiring to deflect us from our task. For example, the last thing we ever expected to have to do was to replace a significant piece of the cartazzi supporting frame on the starboard side which was out of alignment, and this involved literally cutting out the offending section and welding in a fresh newly shaped piece. This was a major piece of surgery with the added requirement to satisfy the relevant authorities that it had been accomplished in accordance with the appropriate technical regulations. Preparation for the locomotive's return to traffic has not been confined to the overhaul though. Training and re-certification of our support crews and on-board teams has also been given appropriate attention in recognition of the degree of skills fade which comes with being absent from the mainline for over two years. Moreover, it will not be lost on you that the vagaries of the overhaul have recently driven a coach and horses through our rail-tour programme. This is a fast moving and fluid situation – as they say

You will read much about *Tornado's* overhaul in the following

pages, but the broad range of other activities we are engaged in deserve equally weighty mention. Although the construction of the P2 has been overshadowed by the overhaul of the A1, we are nevertheless on the cusp of some significant developments, with the tender frames now delivered, and the boiler imminent. We have also had a very successful first phase appeal for the design and construction of the valve gear, and the design phase will now be completed (as promised on achieving the first £50,000 of our target) ready for construction of key components. Our efforts to create a mainline connection at our new works are also proceeding apace, with a recent visit by the Army Reserve in the form of our old friends from 507 Special Team Royal Engineers (507 STRE) completing a significant tracklaying exercise over the course of a recent weekend. We have also had confirmation of a significant tracklaying period to be conducted by the Regular Army from 'local' i.e. Catterick unit, 32 Engineer Regiment. They anticipate being here for four to five consecutive weeks so we should see some significant further progress in this key area. To reiterate what I have said in related correspondence, the mainline connection is a key element in our locomotive management strategy in order to minimize the number of occasions we have to use road transport. As we all know, the latter is not conducive to the welfare of long-framed locomotives.

To conclude, we will of course keep you apprised in near-real time of progress in these and other areas, including the operation of *Tornado*. But my final comment must of course be addressed to you, our wonderful supporters. You are aware that our Trustees and Board members give freely of their valuable time, often at the expense of their domestic priorities, and I am conscious that we have drawn significantly from that well over the last couple of years. What helps to incentivize us to keep delivering is, of course, the considerable support – both financial and moral – that you provide, for which, as your Chairman, I am deeply grateful. TCC

AI FUNDRAISING by Sophie Bunker-James

AI Fundraising – Last Chance to Join the Overhaul Club

Tornado's overhaul is almost complete, and we are anticipating seeing the locomotive in steam at the Great Central Railway for static and dynamic testing. The overhaul cost approximately £1 million and has taken two and a half years, which has naturally seen our earnings reduced through that time. Our generous supporters have sustained the work, but we are now keen to replenish our reserves, and start saving for the next overhaul in five to ten years' time!

Legacies continue to play an important part in our income and these generous gifts help to ensure the future of steam for the next generation of enthusiasts. Organizations such as the National Trust see around 80% of their income arrive in this way. In many ways we are

pleased to report that our legacies amass a much smaller proportion of our charitable donations, however, we are always honoured and grateful to receive them. Whether leaving a donation in your will or making a "living legacy" donation to a specific project in order to enjoy watching the hard work come to fruition, these contributions can make a significant difference to smaller charities such as the Trust.

We thank our Covenantors for their regular donations, they really are the life blood of this organisation and the foundation upon which it was built. Our long-standing supporters will remember when the campaign started asking for £5 a month back in 1990 – adjusted for inflation, that would have the buying power of over £11 today. Against this background, we would be grateful to

any supporter adjusting their monthly commitment, even by a few pounds. Of course, all one-off donations are welcome, and your support soon adds up to enable the A1 to continue its work on the railway.

After considerable time out of the limelight, we will be looking to recruit new supporters on our travels with *Tornado* this year, and at events around the country. If you see the team on railtours, or at heritage railways or showground events, do come and say hello and perhaps even introduce a friend!

Support us at a1steam.com/donation, contact our fantastic Supporters Administrator Janet on 01325 460163 or email supporters@a1steam.com TCC

PROFILE – DAVID ELLIOTT by Graham Langer



David and his father at the RH&DR with Hurricane.

The AI Steam Locomotive Trust succeeded where other new builds struggled because of the way in which it was structured from the outset, "The rules of the organisation would prohibit cliques and any form of élitism. Everyone would achieve recognition based on effort rather than size of cheque book. This would enable all efforts to go into the building of the 'AI'." In essence no person, or ego, could be bigger than the locomotive and this ethos has helped glue a highly successful team together for nearly thirty-five years. A core member of this group from the outset was the project's engineer, David Elliott.

We were deeply saddened, but not surprised, to hear of David Elliott's passing on the morning of the 20th December. David had been suffering from stage four prostate cancer for a couple

of years and was aware that the end was near, signing off with his colleagues at the Trust at the end of September as his condition worsened.

Railways and engineering were in David's blood. One of his grandfathers worked for the Railway Clearing House, the other was a Signaller at Velvet Hall on the Berwick to Coldstream line and subsequently at Belford on the East Coast Main Line. A great grandfather was one Septimus Jennings who after a spell with a set of steam ploughing engines in mid Northumberland established an early Ford dealership at Morpeth in Northumberland which eventually grew into the regional Jennings Ford distributorship.

As a consequence of his father's Northumbrian origin and interest in railways, and in spite of being

brought up in Kent, the LNER was David's favourite company. He remembered visiting his grandparents at Oakwood (near Cockfosters on the Piccadilly line) where he would be taken for a walk in a nearby wood which culminated in a bridge over the East Coast Main Line near Hadley Wood for some spotting. Other day trips from his home in Kent in the late 50s and early 60s would end up at King's Cross or Potters Bar to observe operations. Another regular destination was the Romney Hythe and Dymchurch Railway which had a fleet of Gresley lookalike Pacifics of which his favourite was Hurricane.

One of David's most thumbed childhood books was his father's copy of the 1947 Model Railway Handbook by W J Bassett-Lowke, where on page 65 was a picture of a beautiful 2 1/2" gauge model of *Cock o' the North*. He asked his father to take him to see it and was devastated when he was told it had been rebuilt into a Pacific.

His fondness of East Coast motive power was cemented in 1967 when he travelled on two *Flying Scotsman* railtours within two weeks. On 'The Mercian' railtour on 16th April he happened across Alan Pegler in the buffet car as the train was coming down Stoke Bank at high speed and congratulated him on the 90mph they were doing to which Pegler replied, "Yes, it is a good 80 miles an hour" which was No. 4472's speed limit at the time! As a result, David plucked

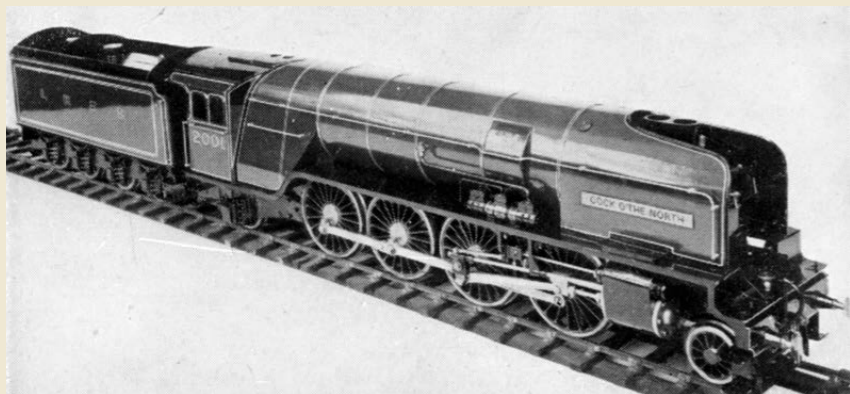

The illustration from the Bassett-Lowke catalogue.

up the courage to ask if there was any chance of going on the footplate during the next trip. Pegler asked David to find him as they were going through Peterborough and, having been escorted through the corridor tender, he spent ten enthralling minutes on the footplate as the locomotive climbed Stoke Bank. Although David possessed Ian Allen ABCs, he found number collecting boring and tended to spend his time trying to understand how the engines worked - which subsequently proved very useful.

After graduating as a mechanical engineer, David joined British Rail at Derby in 1973, becoming a Senior Technical Officer before moving to Leeds in the same role. He moved to Corkerhill Traction Depot in Glasgow as Depot Engineer before leaving the railway to join Westland Helicopters as an Advanced Project Engineer in 1979. After four years in Yeovil, David joined Westland Aerospace's hovercraft division on the Isle of Wight before moving to Pilatus Brittan-Norman in Bembridge in 1988, becoming that firm's commercial manager dealing with the MoD and overseas defense agencies. In 1996 he moved to Adtranz to oversee the signaling installation on the Kuala Lumpur monorail system and during this period became heavily involved with the design and construction of *Tornado*, firstly as a part-time Director of Engineering and, from 2005 to 2008, in a virtually full-time role. David then took on the role of consultant project manager and engineer to head up the construction of P2 No. 2007 *Prince of Wales*.

The main reason David got involved with the nascent AI Trust was that, having come from a modern railway engineering background and having worked with some locomotive restorations over the years, he was not very happy with the way they were being done - particularly the way that old and worn out components (which in a normal engineering environment would be scrapped and renewed) were being painstakingly repaired or restored, not always successfully. Building a new locomotive immediately overcame that problem! He responded following press reports of the launch meeting at York in 1990 and was invited to the King's Cross roadshow in March 1991. On arrival he was a bit taken aback to find that he was sitting on the stage rather than in the audience. As the first professional engineer to join the management group he quickly fell into the role of Technical Director, a post he held, with the odd

change of title, until his death. The construction of No. 60163, and No. 2007 in particular, allowed David to demonstrate his profound knowledge of locomotive engineering and skill as an innovator. *Tornado* represented the very best LNER traditions married to the most modern technology, a process that has seen further advances with the design and development of the P2 which has the most accurate frames of any steam locomotive, a revised leading truck arrangement and, probably David's most impressive achievement, the completely redesigned and improved three-cylinder monobloc. David furthered the development of the modern steam locomotive into the 21st century and it is fitting that *Tornado* is regarded by the rail industry as a fully-functioning, everyday member of the mainline locomotive fleet as much as an efficient steam engine.

There can be little doubt that David's contribution to the railway heritage movement has been huge and he leaves a legacy that is far larger than *Tornado* and *Prince of Wales* combined. Darlington Locomotive Works (DLW) would not have become the centre of excellence it now is without his organizational skills and determination to pass his knowledge on to others, notably Daniela Filová from the Czech Republic who joined the Trust as David's Engineering Assistant and has now branched out to start her own engineering business in Shildon, and Alan Parkin who continues David's work on the P2. It is serendipitous that Ed Laxton, the last DLW apprentice to benefit from



Daniela at work on the P2.

David's guidance, has now found a job at Daniela Works. David faced up to his illness with great stoicism, attending the Works for as long as it was possible and ensuring his data was passed on to Alan Parkin, particularly the detailed design of Lentz/Franklin/Elliott valve gear, as well as recording videos for the Trust's YouTube channels and the 2022 Convention. He also continued to advise Rob Morland during the latter's installation of the European Train Control System (ETCS) on *Tornado* and made significant contributions to the G5 and B17 projects. Many of us will fondly remember his preferred image as the "man in black" through his wardrobe preferences, his passion for the music of Wagner, his droll humour and his willingness to share his enormous knowledge with anyone who expressed an interest. He leaves a widow, Dominique, with whom he moved to Bishop Auckland to take on the AI project. **tcc**



David Elliott, Barry Wilson and others pose for a photo during *Tornado's* first steaming at DLW.

AI OVERHAUL *by Ben McDonald*

SPRING 2024

As the push to complete *Tornado* gathered momentum after the festive break, a working party of volunteers and paid staff were at Loughborough where significant progress was made. All the motion and brake rigging was installed, as well as smaller components, pipework and fittings within the smokebox. Following this week's work, all brake hangers had been installed and many of the brake blocks were now in place.

Top right: The brake hangers in place, motion waiting to be refitted.

Centre: Volunteer Alex Morton can be seen fitting split pins to the brake rigging.

Centre right: A newly fitted brake block, with the little end of the connecting rod ready to be connected to the piston rod.

A further volunteer work party comprising of the Chairman, Trustees, Directors and some of the Support Crew all gathered at the start of February to help prepare for *Tornado's* return to steam, working both on the locomotive itself and preparing the support coach for use once more. On the locomotive, the volunteers' hard work in replacing and lagging pipework, painting tools and various other items contributed to moving the engine closer to completion and most importantly this freed up the more skilled members of the team to focus on areas requiring their expertise. Completion of the pipework in the cab was a priority.

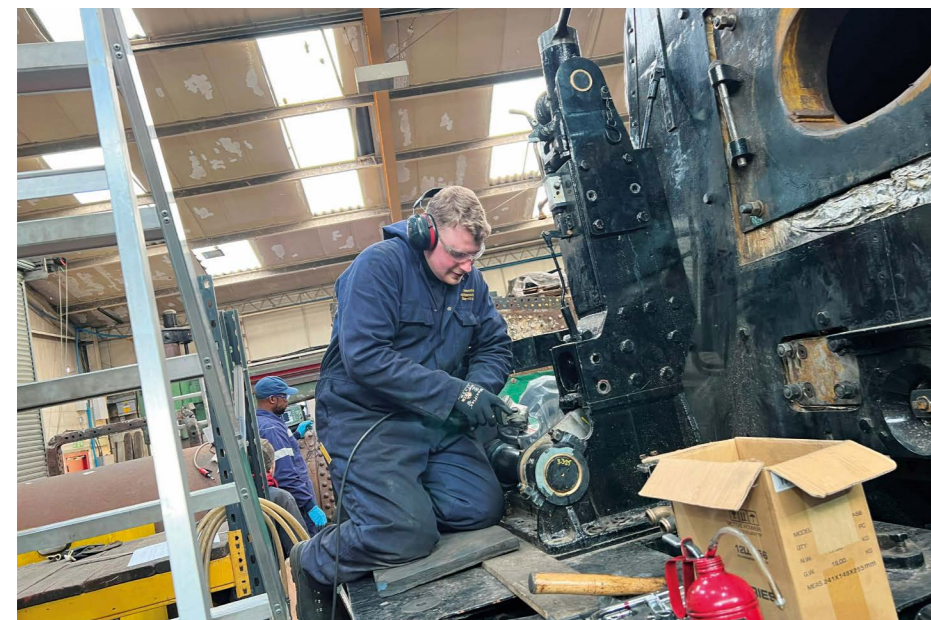
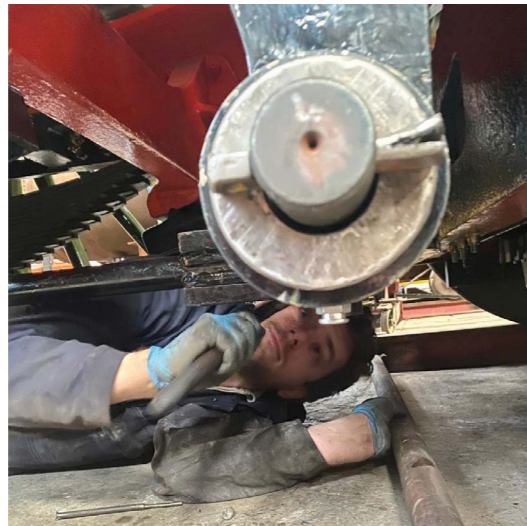

Above: Work progresses on the reverser stand.

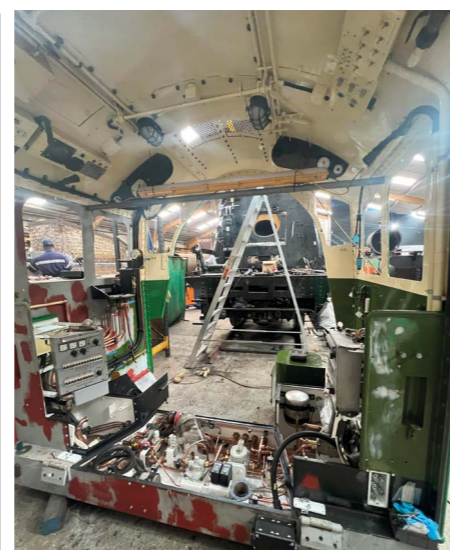

The cab, with most of the pipework in place, ready for relocation on the locomotive.

Top left: With the cab back in place, the pipework and cabling can be seen on the driver's side. Once complete it will be painted and the final cowling fitted over the flexible cable runs.

Top right: The cab floor awaits refitting.

Mid-February saw work in the smokebox continue to focus on the spark arrestor screens. More steelwork arrived for these as part of the kit and a lot of the effort spent on the tricky task of getting the parts of the plating cut to infill the gaps around the main steam pipes and the smokebox sides. Additionally, work was advanced on the steam feed pipe for the second turbogen feed to allow the team to move onto the preparation of the cab for final painting both inside and out.

Centre, below left & right: The superheater elements are refitted with the Chairman getting some 'hands on' experience inside the smokebox.

With work on the manifold taking up space above cab floor level, a team was able to work below floor level to start refitting the injectors and replacing some of the large bore copper pipework. The joints on this pipework have worn overtime as they have been taken up to remain steam tight and now need replaced. The opportunity was being taken to move these joints up the back head pipe so that they are easily accessible from the cab floor level. The previous location had them positioned below cab floor level making access very tricky. With the final pipework of the ETCS system fabricated for the cab, this was stripped the enable final painting to be completed before being married with locomotive again.

The Support Coach had something of a makeover, and we are closer to being able to use it fully again. Some items were identified that needed to be replaced or repaired and the upholstery and kitchen are now cleaner than they have been for a while! The workbench over the generator received a coat of paint and the collection of tired and unusable coats and jackets accumulated in the workshop were removed. The batteries were topped up and charged once the coach was back on mains power and fuel was added to the generator fuel tank to allow this to be run up and checked.

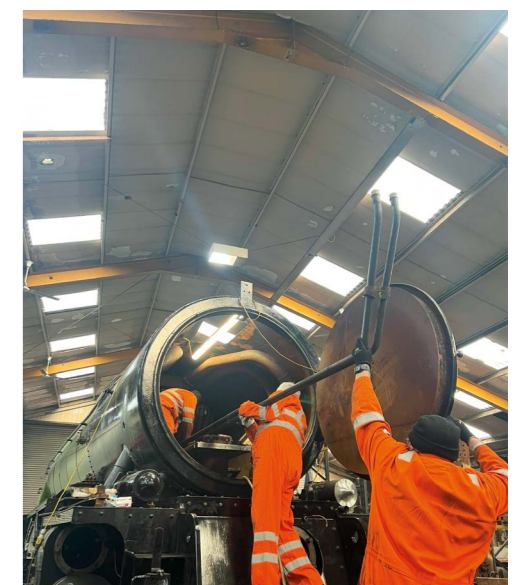
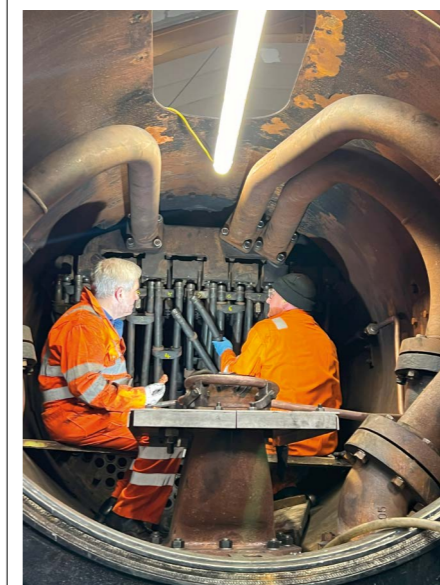
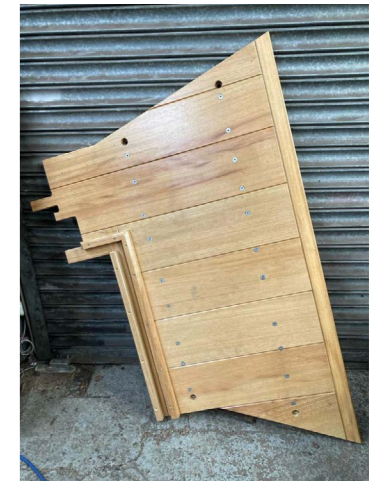

Top left: An example of some of the complicated pipework before it was replaced on the locomotive.

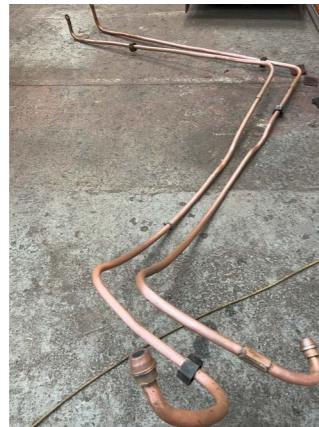

Top right: Larger gauge stainless steel tubing being fettled.



Centre left: One of the valve heads has its rings fitted.



Above: The rest of the motion back in place, just awaiting connecting to the crosshead.

SUMMER 2024

Tornado's move to the Great Central Railway (GCR) at the beginning of summer was delayed by unanticipated challenges in the area of coded welding, a matter that has affected a number of heritage railway projects as well as our own.

On reassembly of the boiler and its fittings, we needed to undertake some work to the gauge frame pads. Due to the paperwork required and the level of welding necessary, this was not the straightforward task we had anticipated as our regular welder was no longer available to us. It proved exceedingly difficult to source a qualified coded welder for the task, as within the small pool who could undertake the work, personal circumstances delayed progress and the plan to complete this work changed numerous times.



Tornado, reconnected engine and tender, in the shed at Loughborough on the GCR.

Once the gauge frames were secured, it was appropriate to undertake a hydraulic test to reset the seven-year ticket. This took place on Wednesday 1st May. The boiler passed the hydraulic test, however one stay on the righthand side was weeping, suggesting a very small crack. The boiler has had several hydraulic and steam tests, and this had not presented previously. The stay was removed and, as is necessary, the team then inspected the surrounding stays (as they can suffer damage compensating for the adjacent cracked stay). A reasonable number were found to need replacing. This raised concerns for the left-hand side of the boiler, and we subsequently found a smaller number that required replacing on that side.

We again suffered from the availability of skilled welders to carry out this work but it was complete in mid May. *Tornado* left the Locomotive Maintenance Services (LMS) works bound for the GCR, on 23rd May.



David Wright and Andy Morgan from LMS work to reassemble the brake equipment.



Tornado on arrival at the GCR in May 2024.

Following arrival at the railway, there have been many small snagging tasks, such as cupboard doors to rehang and painting touch ups, which have needed to be resolved; we are happy to report that the vast majority of these are now complete.

Subsequently, there have been numerous jobs to be undertaken as the engine and tender have been reunited, the most challenging of which has been the testing and commissioning of the air brake system. The extra requirements of the new ETCS system have created additional challenges and have needed more time from our team to resolve. After some delays we now have a working brake system. The delays have centred around the 'overcharge' element of the air brake system, which after a thorough investigation has now been resolved, and with the electro-pneumatic (EP) valves that activate when the TPWS or ETCS systems apply the brakes. The current design, updated to accommodate ETCS, is not braking as swiftly as is legally required, with a modification to the design needed. In simple terms this is likely to be a larger EP valve to enable a reduction in the time

taken to apply the brakes. A confirmation of the change to design is close at hand and then the installation will be planned in. The good news is *Tornado* is now able to work on preserved lines, and once the above change is made the brake system will be certified for use on the main line. It is naturally frustrating to find that the design needs changing, but this is perhaps to be expected with a Pathfinder project accommodating such a comprehensive change to incorporate ETCS. At the beginning of July, the stay tell tales were cleared within the boiler, in preparation for the first warming fire to be lit within *Tornado's* firebox since its rebuild, signalling the next stage of commissioning as we conclude the overhaul. We are now on the final straight in preparation for the testing of the steam system, dynamic testing and running in. As soon as the locomotive is weighed, a warming fire will be lit. There will then be a period of static testing, including some ETCS tests, before the locomotive undertakes running in on the GCR. We have kept a close liaison with the Nene Valley Railway and arrangements are



Gauge glass showing the boiler topped up ready for steaming.

in hand to arrive at Wansford at the end of the second week in August ready for the planned visit. *Tornado* will then need a washout and any final activities before undertaking main line test runs. **TCC**

ETCS UPDATE by Rob Morland

With support from Ian Greenan, Andy Meredith and David Wright, the week of 8th to 12th January has seen the completion of a programme of electrical work at LMS. This included the following jobs:

- Fitting the new 32mm fixed conduit to replace the life-expired flexible linking the centre frame stretcher box to the fireman's side conduit system behind the battery box
- Pulling through the existing wiring loom and re-terminating all the wires
- Fitting the renewed flexible conduit to the lower centre marker lamp, wiring up the lamp and the forward-facing camera power supply
- Refitting the fixed conduit around the smokebox to the centre top marker lamp and wiring up the lamp
- Refitting all the frame-to-cab cabling
- Testing the shore power inputs to the Essential Services (ES) and Auxiliary Services (AS) supplies
- Fitting the headlamps and testing all the front lamps
- Testing the steam chest temperature gauge
- Running both turbogens on air and testing the Turbogen Switch Box tachometer and protection circuitry
- Testing all the engine electrical systems
- Testing the rebuilt sander indicator circuit on air
- Testing the atomiser steam indicator circuit

Andy Meredith made up the new 32mm fixed conduit to replace the previous flexible that connects to a box on the rear frame stretcher and passes through the frames just behind the AS Battery box to deliver cross-engine wiring into the cab. The previous Adaptaflex flexible conduit had rotted internally due to ingress of slacker pipe water from the cab above. We successfully pulled the existing loom through the new conduit and this was re-terminated on the two original connectors.

Work then moved to the front of the engine where Ian Greenan installed the lower centre marker lamp housing and lamp bracket, and the upper centre marker lamp housing and conduit around the smokebox. The marker lamps were then rewired, the lower one includes the power supply to the forward-facing camera, which is located in the back of the marker housing. A new flexible conduit was fitted for this, together with a set of elbows to allow connection into the existing conduit box port. The refurbished headlamps were then refitted and all the front lighting systems were tested. The wiring to all the tender lights was also tested through to the engine-tender umbilical connector. The only fault found was with the hazard warning flasher relay to the daytime headlamp, which has obviously not survived its move to the new ES Control Panel. Fixing this will involve a new flasher module. The original one was the first electronic module built for the engine in 2008 and was 'potted' to avoid moisture ingress and protect against vibration, meaning that the relay can't simply be changed. Fortunately, a spare was built at the time, so this will be used now.

The next job was to test the re-located steam chest temperature gauge sensor circuit, now housed in the new Turbogen Switch Box. This location avoids the need to run a dedicated thermocouple cable the whole length of the engine. It now just requires the two wires



Above images : New turbogen mounted on the driver's side front running plate.

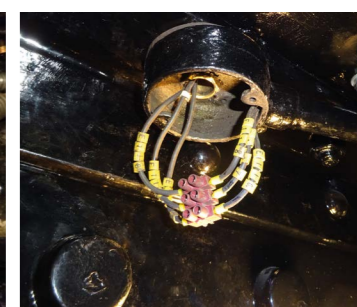

Above left: New flexible conduit and connector for the lower front marker, also showing the front buffer beam umbilical cable and connector.

Above right: Wiring for the upper centre marker lamp.

Right: Rewired lower centre marker lamp and forward facing camera power supply.



that operate the meter in the cab. These have been taken from our set of installed spares. Placing the sensor in a cup of hot water registered 50 degrees C on the gauge, showing that this is working correctly.

Testing proceeded around the locomotive with all the essential and auxiliary circuits being switched on and checked. All the auxiliary connections to the tender were tested through to the engine-tender connectors. The Shore Power inputs on both sides of the engine were checked, and the cross-feeds between the ES and AS supplies were tested. Everything worked correctly.

The next job was to re-connect all the wiring to the Turbogen Switch Box (disconnected to allow welding in the adjacent smokebox) and test the turbogens. David Wright made up a new interface coupling which enabled the shop air supply to be coupled to the turbogen steam inputs. We ran up the new turbogen, which was initially a little stiff and wouldn't make full speed on the available air pressure. However, it soon warmed up and, when restarted, ran at the correct speed under control of



Above left: Replacement fireman's side cross-engine conduit with loom ready for re-termination.

Above right: Entry point of new conduit behind AS Battery Box.



Above left: Loom connected in to harnesses and protected with braided sleeving and right, AS conduit box with all harnesses in place into the cab above.



Testing the front head and marker lamps.



Testing the front tail lamps.



Testing the front centre headlamp.

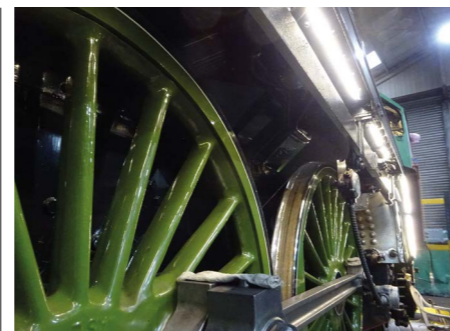

Outside frame lighting under test.



Steam chest temperature gauge probe in hot water.



50 deg C registered on the cab gauge.

its governor. After checking its output voltage we reset the over-voltage trip and were very pleased to see that it operated the new tachometer start-up circuit correctly, first illuminating the 'Up to Speed' LED and then around 35 seconds later the 'Online' LED. This new delay timer allows the turbogen to fully stabilise before automatically connecting the electrical loads, which should reduce the amount of crew intervention needed when starting up the turbogens. It will also automatically disconnect the loads in the event that steam pressure reduces to the point where the turbogen speed reduces below around 3000 rpm.

We then checked the feeds to the ES and AS I/O Panels and all was working correctly. We applied loads and the turbogen powered these without a problem. We then transferred the air supply across to the old turbogen (on the fireman's side) and repeated the process. This turbogen has been refurbished at DLW and fitted with a new turbine wheel, designed by Alan Parkin. It also worked correctly, operating the tachometer circuit and supplying power to the ES and AS I/O Panels. The tachometers showed the new turbogen to be operating at 3750 rpm (exactly according to the Meiningen specification) and the old one at 3700 rpm, which is well within its specified working range. These tests demonstrate the full operation of the Turbogen Switch Box, so we can have a good level of confidence that the new two-turbogen system will work correctly when the loco is steamed.

We then proceeded to test the rebuilt sander indicator circuit. This was connected up and the forward and reverse pressure switches were tested on air to check that they operated the flashing LED driver alert. They both worked correctly. David Wright will now arrange for a new bracket to be made up to mount the control box. This is required as the old box mounted to the assembly that supported the TPWS Dual Cab Card enclosure. With the installation of ETCS this has been relocated to a position under the driver's seat, so the mounting position no longer exists.

Our final job was to test the atomiser steam indicator. This illuminates a red warning LED on the AS Control Panel when there is no atomiser steam pressure, and a blue one when pressure is detected. On connecting air to its steam input a fault was identified in the pressure switch. It is located inside the frames below the smokebox on the fireman's side and is exposed to a tough environment, so it has done well to work for over 12 years. A new switch will be fitted.



New turbogen generating for the first time.

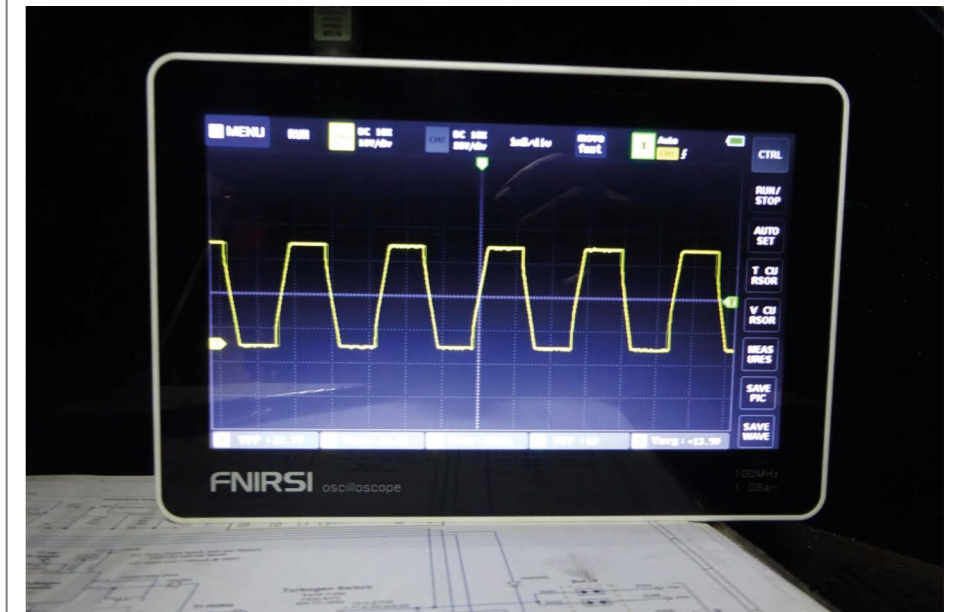

New turbogen tachometer output waveform.



New turbogen up to speed and delivering power to the electrical system.

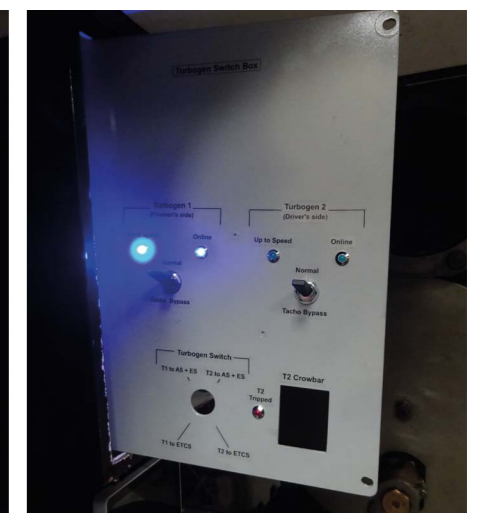

Old turbogen up to speed and delivering power to the system.

Completion of these jobs signals the electrical work on the engine coming to a finish. Now that the cab is permanently installed, the wiring connections have been made between the cab and frames. The access hole between the cab and frames on the fireman's side has been sealed with a rubber gaiter and silicone, to prevent slacker water entering the conduit system.

Further ETCS technical and electrical updates from GCR will feature in the next issue of TCC.

Top right: Old turbogen connection box, testing the crowbar tripped LED.

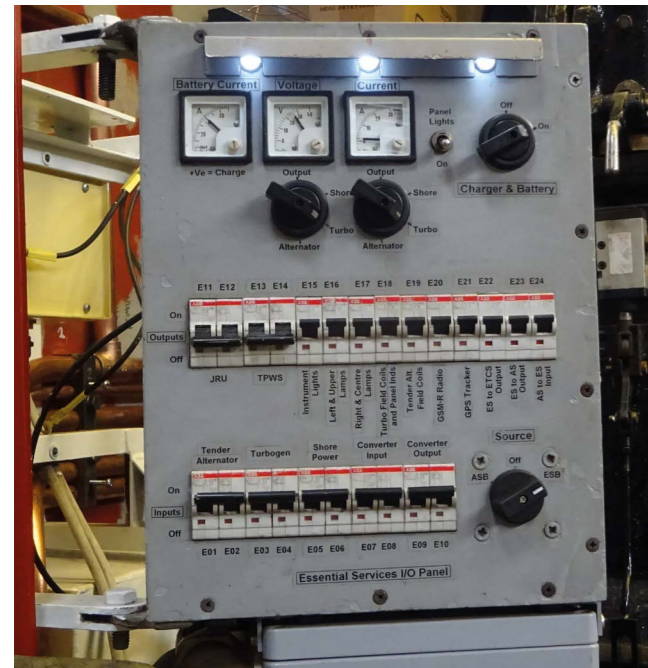
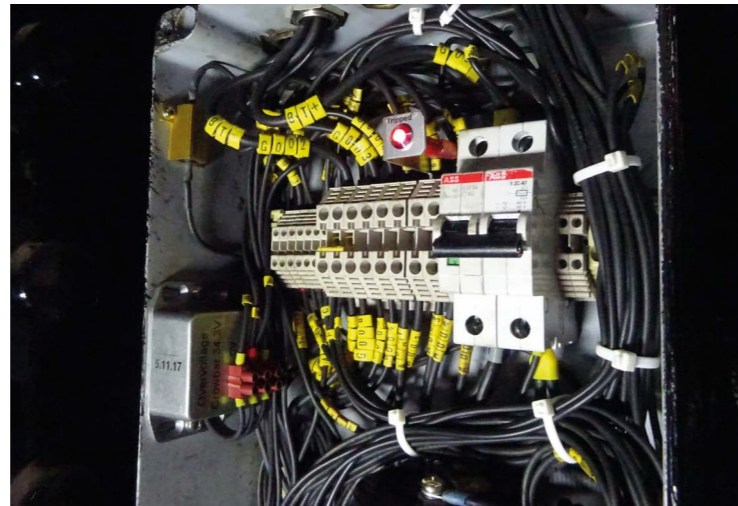

New turbogen power delivered to the ES I/O Panel.

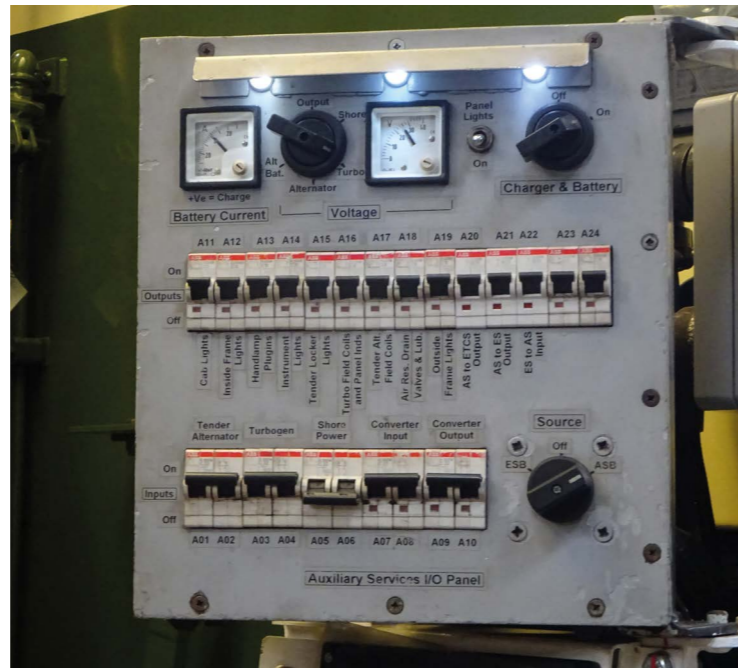

New turbogen power delivered to the AS I/O Panel.



Above: Old turbogen under test with air.

Right above: Extended harness to connector SKA11 in place behind the AS I/O Panel.

Right below: Atomiser steam pressure switch on the inside frame under the smokebox (to be renewed). TCC



JORDAN HEJAZ RAILWAY VISITS THE AISLT



Steve Davies, Chairman, and Huw Parker, AISLT Operations, host representatives of the Jordan Hejaz Railway at DLW.

Towards the end of June, The AI Steam Locomotive Trust hosted a delegation from the Jordan Hejaz Railway (JHR), who were keen to better understand the UK approach to Heritage Railways. The original Hejaz Railway opened in 1908 and was planned and funded by the Ottoman Empire to support Muslim pilgrims performing the Hajj, a religious pilgrimage to Mecca. However, the railway clearly had significant strategic potential in a region where long distance travel across inhospitable desert and mountainous terrain was very challenging. The line was built to 1050mm (3ft 5¾ in) and is the single railway line remaining in Jordan today. The Hejaz Railway is most famous for being the main target of attacks by Capt TE Lawrence in the Arab Revolt during World War I and many sections to the North and South of Jordan are no longer in use.

JHR is seeking to revive use of the railway for both tourism and commuting. The aims of their UK visit were to examine how Heritage Railway operations function in the UK, investigate the railway museum

experiences provided in the UK and to see some examples of modern railways – high speed, underground, light railways (London Tramlink and Docklands Light Railway) and suburban railways. They still have strong heritage links as they maintain a fleet of eight oil-fired steam locomotives alongside several GE diesel locomotives.

Prior to their arrival in Darlington, the team visited the Great Central Railway, where they were able to see *Tornado*, as the locomotive approaches the end of her extensive overhaul. They discussed the advantages of a new build locomotive and the addition of improvements to the original design and the installation of modern signalling equipment and were impressed to see what had been achieved.

After a visit to the National Railway Museum the previous day, the delegation visited the new Locomotive Works in Darlington and after a short presentation about the build of both *Tornado* and *Prince of Wales*, a short update on the Hoptown development and plans for 2025 celebrations they toured the new building and inspected

tracklaying progress outside the shed. At the end of the visit, we exchanged some small gifts for those involved and the delegation left to travel by LNER down to London and complete their visit with some exposure to a variety of modern traction. TCC



TRIBUTES TO DAVID ELLIOTT

Steve Davies

It is no exaggeration to say that David Elliott was a pioneer of new build steam. Since he began volunteering 1991, David has made possibly the greatest contribution to the objectives of The AI Steam Locomotive Trust of any one individual, and in so doing has paved the way for new build projects in the UK and overseas.

We were not surprised to hear of David's passing in December as, in his characteristic pragmatic style, he had informed those working within the Trust, and its supporters, of his prognosis after being diagnosed with prostate cancer a couple of years ago. Nonetheless, we are deeply saddened to lose a dear friend and quite brilliant colleague.

It was during the latter days of David's aviation career that his relationship with the AI Steam Locomotive Trust gathered pace – initially in a voluntary capacity – becoming heavily integrated in the design and construction of *Tornado*. David was concerned about some preservation practices of the time, seeing old components painstakingly restored when a new one would have been much the better and cheaper solution, and was therefore most interested to see an advert for a project promising to build a whole steam locomotive from scratch – and an LNER A1 to boot! He responded offering his services on contracts and commercial aspects and was invited to the King's Cross roadshow in March 1991. On arrival he was surprised to find that his seat was on the stage rather than in the audience! As the first professional engineer to join the management of the Trust, he adopted the role of Technical Director – whilst the job title changed through the years, David held this post until his death.

For virtually the entire construction period, David was the driving force behind the Trust's major engineering efforts. In each case, his philosophy was to take the original drawings and adapt and redesign them to incorporate modern technological and fuel efficiency measures but keeping the externally elegant appearance unaltered. The result has been, in the case so far of *Tornado*, an exceptionally efficient and powerful steam locomotive with very high degrees of reliability, which is essential when operating on Britain's high speed main lines. His personal drive, innovation, imagination, and ability to enthuse those around him, has resulted in a locomotive which in all respects is a natural recreation of how the steam locomotive might have progressed if it had remained in regular service.

David's presence during main line operations, discussing issues with crews, has been of major reassurance. One particular run of note was the occasion in 2017 when Network Rail granted permission for *Tornado* to 'go for the Ton'. Between Thirsk and York, the locomotive achieved an incredible post-steam era record of 101 mph, thus delighting and thrilling a large section of enthusiasts and non-enthusiasts alike, bringing much kudos to the Trust specifically and UK railway heritage more generally. This would not have been allowed without the high degree of faith the industry placed in David's engineering capabilities.

Tornado is being fitted with the new European Train Control System (ETCS), the first steam locomotive in the world to receive this state-of-the-art digital in-cab signalling system. If steam is to survive on the mainline for the long term, then it is essential that ETCS be fitted, not an easy task in the hostile environment resulting from steam, heat, hot water, oil and ash.



Passing on the baton, David presents Ed Laxton with his apprenticeship papers.

David was central to the integration of this highly complex system, demanding even greater supplies of electricity than the locomotive has hitherto been capable of generating, all to be fitted discretely, and it is no exaggeration to say that the task of Network Rail and Thales (the international electronics contractor) has been made significantly easier through David's imaginative, can-do, and untiring engagement.

Once *Tornado* was complete, David had the opportunity to right a long standing wrong! One of David's most cherished childhood books was his father's copy of the 1947 Model Railway Handbook by W J Bassett-Lowke, where on page 65 was a picture of a 2 1/2" gauge model of *Cock o' the North*. He asked his father to take him to see it and was devastated to hear that the P2 had been rebuilt into a Pacific. David's work on P2 Class, No. 2007, has been even more in depth than that required on *Tornado*. To make the new P2 viable, David completely designed-out the original challenges, and with the aid of 3D CAD and computer simulation such as CFD has demonstrated to the rail industry that the locomotive will be a remarkable performer. His crowning glory was the complete re-design of the three-cylinder monobloc which, in its original form, was sub-optimal in its performance. The cylinders were also physically too wide for today's railway, with the chance of making contact with platform edges. David has redesigned the cylinders, innovatively using a 3D printed model to help inform the building contractor of the correct approach to fabricating this highly complex component. Its delivery last October undoubtedly marked the culmination of David's contribution to the UK's steam heritage scene, in spectacular fashion. Work will begin later this year constructing David's final design, the complex valve gear, the component which will make the P2 Britain's most powerful steam locomotive. David went international with his research, with critical information from South Africa and the United States aiding the redesign. Such is

the significance of David's influence on the new locomotive that it will forever be known as the 'Gresley-Elliott' P2. A supreme accolade and personal tribute.

David's engineering accomplishments were only outshone by his warm and friendly personality, coupled with his wit and good humour. He always had time to explain his work, and has enthralled numerous enthusiasts with occasionally lengthy, yet always accessible, presentations on his beloved locomotives and their key design features – wearing his trademark black shirt! He passed on his skills to those with whom he worked, always seeking to educate the next generation, and we are fortunate that his knowledge was shared with individuals who will continue his work on the P2. We have been moved and humbled by the outpouring of respect and support since David's death. David leaves a widow, Dominique, with whom he moved to Bishop Auckland to take on the AI project. There will be no formal funeral, but a memorial service is likely to be held in the spring.

David Champion

I remember vividly David's handwritten letter arriving at my home shortly after the November 1990 launch. He was living



in the Isle of Wight and was working for Pilatus-Britten-Norman who built the Islander aircraft – but he was also a former BR Graduate Engineer. A qualified Railway Engineer with knowledge of modern industrial planning and production methods sounded

like just the sort of person I wanted so initially I asked him to act as our Contracts Adviser and could he please come to the AI Roadshow at the Great Northern Hotel, King's Cross. Sensing David's ability as a good communicator, rather unfairly I asked him at short notice to address the audience on how he anticipated he would manage the future contracts to build the new A1. David instantly delivered a very comprehensive and impressive account of how he viewed the tasks ahead. His contribution was crucial in helping establish that we were a hard-headed professional team bent on using the best of modern manufacturing techniques to build, not a replica, but the 50th A1 capable of certification for running on the main lines of the 21st Century.

As the project headed into its first years David stepped up to lead the engineering side. As he was still working in aviation David initially worked alongside the immensely talented Bob Meanley, (the then Head of Engineering at Tyseley), until later on in the 90's when he could dedicate his career, full time, to the AI Trust. As David got into his stride the benefit of his modern industrial experience came to the fore. He pioneered so much in using modern manufacturing methods, and demonstrated a wisdom that has been to the benefit of the whole steam movement.

The Trust's first problem was to establish that the original drawings existed at the National Railway Museum (NRM), but all the LNER drawings were in a disorganised heap in the NRM basement and the NRM insisted that the drawings were too

fragile to go through the rollers of a conventional plan copier of the day. Here David made the first practical demonstration of his skills. A team of AI volunteers went in and sorted and catalogued all the LNER drawings (the NRM charging us £2,500 for the privilege of sorting out their archive for them!), then David brought in a state-of-the-art digital flatbed scanner that meant the plans could be digitally copied without harming them. The data was transferred to magnetic tape and from there uploaded on to CAD (computer aided design), a heritage movement first. David downloaded digital information from our computer to British Steel's computer, Dorothy Mather (Peppercorn's widow) then pressed a button and the darned thing just whizzed off and cut us a huge pair of mainframe plates!

One day in 1993 David came to a Board meeting in my office where he spread out a paper printout

of his computerised build plan, which, from memory, was about ten feet long and three feet deep. It detailed all the tasks needed, with all the dependencies of each task, ultimately resulting in a brand new A1. It was a masterpiece of planning, and it could be used to build other brand-new main line steam locomotives from scratch. As construction speeded up the use of CAD produced more firsts in our movement. Many will remember time around 1993 when a railway magazine featured the very first 3D illustration showing the AI frames, where all the stretchers and components required for the 'keel' of the locomotive were clearly shown in colour. The impact was tremendous in aiding fundraising and sponsorship, and now virtually all 'new build' projects, even the American 'T1' build, adopt this approach to clearly display the task in hand.

As time went on David's ability to enthuse and enthrall our supporters played a great part in the Trust's credibility but was also a major help in bringing on sponsors – a massive benefit. David unlocked more sponsorship than any other person around, including our principal sponsor Andrew Cook, who also early on recognised David's abilities and talents. So, we got our A1 and David also brought us the P2 where he continued to innovate. The 1990's style CAD that he had used to build *Tornado*, revolutionary at the time, only worked in two dimensions. For the P2 he introduced three-dimensional CAD which allowed, for instance, the ability to plan pipe and wiring runs that would not conflict with each other or any of the other components on the locomotive. However, the most astonishing use of this technology was when David was planning the P2 build against the background of an uncomplimentary legend relating to their riding abilities, so computer software was used to build a virtual model of the locomotive and simulate the passage of a P2 up the East Coast main line to forecast the ride quality and its effect on the track. This information was then used to demonstrate to the certifying bodies that a modification of the pony truck (essentially to a V2 design), would be beneficial and cure historically reported problems. And so on and so on, David just continued to think out of the box, culminating in his masterpiece of the massive P2 monobloc cylinder casting – redesigning it as a welded fabrication as there is now no foundry able to cast all three cylinders in one huge piece.

I think it is fair to say that although David Elliott started off with the AI Trust as a very competent engineer across various genre of transport, he grew with the project until he became a unique authority on the building of brand-new main line steam locomotives. Besides all of this, of course, he just a

really nice guy and it was always a pleasure to be in his company. It is desperately sad that he died before the completion of his beloved P2, a Gresley/Elliott masterpiece. When he last addressed the A1 Covenantors at the opening of the new Darlington Locomotive Works in August, he spoke with such courage, knowing that his life expectancy was only a few months, not years, but he still had the ability to explain, educate and enthuse. No one who was there will forget his last great speech.

A true hero of the Heritage Steam Movement who will be sadly missed. On a personal note it has been a privilege to have enjoyed his buoyant, ebullient company on so many occasions. I hope that even now, somewhere, David and Peter Townend are discussing the springing on LNER Pacific bogies.

David Burgess

We all know about David's expertise as an engineer in aviation and railways, but he had other talents and interests and I was fortunate to see and experience a different side to him that many in the Trust could not.

Trustee meetings used to be held on Saturdays at DLW and once finished, everyone went home except me as I could not get back home that day. On numerous occasions he invited me to join him and his delightful wife Dominique for company on the



Saturday evenings. Often it would be an evening in his local pub, sometimes with works volunteers who lived locally. He was always a good raconteur and host as he was always relaxed and comfortable with people and treated everyone alike and never in my experience treated the volunteers as if he was the boss. He had a sharp wit and an impish sense of humour but which was never nasty or sarcastic.

David rarely talked about himself and his other interests, (Did you know he was once a local councillor where he lived?) but we discovered we both had a common interest in classical music and several times we went to concerts on my Saturday layovers. Once at The Sage at Gateshead I met his late mother. Although elderly, she was sharp, intelligent, friendly and amusing. David was obviously "a chip off the old block".

One recital we attended at The Bowes Museum was performed in an intimate setting and we were in the second row. In the front row immediately in front of the performers was a blind gentleman whose large guide dog was on his rug quietly resting during the concert. The singers (a world class soprano and counter tenor) had just launched into a Handel aria when the dog sat up, yawned loudly and then very vigorously scratched his ear. Everyone laughed, including the singers, but none louder than David. Not always the serious engineer we knew him to be.

When we held events in DLW David often brought in two very large white Hi Fi loudspeakers which not surprisingly, he had built himself. They often stayed there for some days and on one occasion when I was there and with a group of regular

volunteers at work, he played, some heavy Wagner (The Ride of the Valkyries if you are interested) at high volume without telling them first. The workers, whose normal fare was Radio 1 or 2, decided it was time for a tea break and went out into the field. Meanwhile, David and I enjoyed the magnificent sound in that cavernous building.

I am ever grateful to him (and Dominique) for his hospitality, humour and companionship. He was, without doubt one of the nicest people I have ever met or worked with. It was a great pleasure to have known him.

Chris Walker

I knew David Elliott since I first got involved with the Trust as a volunteer in 2008. Whilst interested in railways from an early age, I had no background in engineering or the railway industry. I have to say that, in my opinion, David did more than anyone to educate non-engineering Trust volunteers and members of the general public, who have been fortunate enough to spend time with him.

He had the wonderful ability to talk to anyone about technical matters, irrespective of their level of knowledge and I know that he had many admirers amongst the engineering fraternity. What is possibly less well known are the numbers of those who thought that they would never understand the workings of steam locomotives until they met David. He had an innate ability to judge a person's level of knowledge and adjust his conversation to suit. This was never patronising, merely a desire to ensure that he passed on as much information as required in a way that the recipient could absorb and understand. It was a truly remarkable gift. I know that I, and many others, have asked a question, not expecting to be able to comprehend the answer, only to be surprised by David's patience and ability to explain, inevitably resulting in the person who asked the question thinking "I understood that!". On behalf of those he has, over the years, spent much time educating in the workings of *Tornado* in particular, I would like remember David for his patience and expertise in communicating technical matters to non-technical supporters of the project. If I had to sum up David, I could do no better than say "He was such an incredibly nice man". It was a pleasure to know and work alongside him over the 15 years I knew him.

Rob Morland

I first met David at an A1 Trust board meeting at King's Cross on 19th February 1994. I had (probably unwisely) replied to a letter in the Railway Magazine from David Champion, then the Trust's Chairman, asking for help in putting together a project plan to build a new steam locomotive to operate on the UK main line.

My previous steam experience had all been on Welsh narrow gauge, but in my day job I constructed and managed Microsoft Project plans for a number of projects, so I thought I would write in and see what happened. I received a very quick reply, inviting me to meet with members of the Board at the old Great Northern Hotel at 14:30hrs on the following Saturday afternoon.



David was present, along with David Champion, Barry Wilson, Bob Meanley and a number of others. I was surprised and impressed by the technical skills and knowledge displayed by David and Bob. They described the project to me in such a convincing way that I was immediately hooked. Our first task was to construct the project plan. This was done by David, Bob and me during a weekend in early March 1994 at Jim and Fiona Kirkman's home. The result was, we believe, the world's first electronic project plan to build a steam locomotive. It was ready for action in less than two weeks.

Of course, many pundits at that time thought the project would never be delivered. However, with David's and Bob's skills and enthusiasm I was never in any doubt. I went on to work with them to maintain and update the plan as the locomotive frames were assembled at Tyseley.

It was David's quiet enthusiasm and extraordinary breadth of knowledge that convinced me on that first day at King's Cross that the project was feasible, and as we worked closely together during the 1990s, the progress we made just confirmed that it was only a question of time, and money, before we finished the job.

Fortunately we had a brilliant team to complement us. David Champion was the perfect Chairman and Mark Allatt created the excitement in the hearts of the public which led them to open their wallets and donate and of course Barry Wilson managed the finances and balanced our need for funds against the Trust's ability to raise the money with great skill and not a little diplomacy. Wreford Voge also contributed his knowledge of the UK tax system to ensure that Gift Aid multiplied the value of donations through contributions from HMRC. There is no doubt in my mind that this was the team to deliver an A1. Everyone had a part in that success, but it was David Elliott who actually built the locomotive, and that deserves special praise.

One of David's great qualities was his readiness to accept ideas from others. He was skilled at attracting talented people, putting them at their ease and inspiring them to work with us to give their best. He formed a strong and enduring partnership with Ian Howitt, who happened to be an old friend of mine from the Tallylyn. They were very different characters, but complemented each other extraordinarily well. If the build hit a problem it was only a question of time before Ian came up with a practical and ingenious solution to solve it. They were a winning combination.

As we approached completion of the mechanical build in 2006, the Board asked David and me what we planned to do about an electrical system for the locomotive. Being an electrical engineer by training, this was the first opportunity for me to apply some of this knowledge to the A1. But I had never worked on railway electrical systems, so it was David who contributed his experience to drive the bold ambition which has developed into the unique A1 electrical system. We began with a typical David initiative – we went and talked to others about what they had done. We visited Bob Meanley and heard about his pioneering work to bring the Arrowvale OTMR to steam locomotives. We visited the *Duke of Gloucester* team to understand their approach to the *Duke's* electrical system. Everyone told us that steam and electrics were challenging bedfellows, and the best we could do was to "build everything as strong as we could, then it might survive."

I recall being unsure at that point how much we should put onto the A1, but David was undeterred. He found that DB Meiningen had coupled a modern truck alternator to an existing

small Fabeg turbogenerator and gave us a power generation platform that would support a more comprehensive electrical system than existed on any other UK steam locomotive. He also found a source of Stones axle-driven alternators on redundant parcels vans and had the presence of mind to include a multi-V belt pulley on the rear tender axle to drive one of these.

So it was David's vision which gave us the foundations on which to build the A1 electrical system. He encouraged me to push boundaries – we were to be the first locomotive of any type on the UK railway to feature all LED lighting. We were the first to offer unlimited endurance by powering our essential systems (AWS/TPWS and OTMR) from batteries charged by multiple on-board generators. And it was David who provided the battery boxes on either side of the loco which enabled us to implement a fully redundant power supply – another first for UK steam.

After all the excitement of the A1's first steaming in 2008, and entry onto the main line in 2009, David and I settled down to look after the locomotive in service. However, we didn't stand still and with David's encouragement we continued to add more functionality to the electrical system as requested by crews and the operating team. This process of continuous improvement continues to this day and is very much a legacy of David's commitment to always get better at what you do.

Before long, attention turned to our support coach. David and I had both experienced the frustrations of poorly-performing electrics on hired-in coaches, and we determined that ours would be different. David encouraged Paul Depledge and me to design and build the most comprehensive support coach electrical system on any UK heritage vehicle. It turned out to be a challenging project, but with David's support we were able to deliver a result which seems to fit the bill. If it wasn't for his unswerving confidence we might easily have been persuaded to fall back on a compromise design which would not have delivered the functionality that we enjoy today.

And even after David's cancer diagnosis told us all that he had limited time with us, he continued to give generously to new projects. The P2 story is being told by others, but his assumption that we would implement an electrical system at least as comprehensive as that on the A1 has given us the remit to push boundaries once again.

And over the past two years his contribution to the A1 ETCS project has been significant and essential. His knowledge of the locomotive and breadth of technical expertise has presented a uniquely professional face of the heritage sector to the big railway. It has enabled the East Coast Digital Heritage & Charter team to move forward with the world's first ETCS implementation on a steam locomotive. Alan Parkin and I could not have realised the complex mechanical changes needed to accommodate the system without David. And his professionalism has allowed us to push for the most robust solution to the many challenges that the project has faced.

In particular, his expertise in the braking system has enabled the project to come up with an optimised solution that fits within the engine's space constraints without compromising on performance. We could not have done this without David, and it is very sad that he won't be around to see the A1 haul its first train out of King's Cross under ETCS.

Fortunately, we have many photographic and video records of David talking about the locomotives that he created and loved. These, along with his comprehensive document archive, contain much valuable information that will serve us well into the future.



David Elliott and Rob Morland accept the John Coiley Award for engineering at the HRA dinner in 2018.

However, I am already missing the ability to just pick up the phone to him when I have a question, in the certain knowledge that he will either be able to answer it instantly, or it will take him just a few minutes to find the right reference. And I will also miss him acting as a wise sounding board for new ideas – always encouraging but never over-ambitious in his advice. I don't expect this combination of skills to be replicated by anyone else during my lifetime.

David – you were the very best colleague and friend that any fellow engineer could wish for. You are already sorely missed.

Mandy Grant

Mark and I first met David back in 2013, when we started volunteering for the AISLT. Right from the start, I distinctly remember thinking what a down to earth, approachable, patient and genuinely nice person he was! I have never met anybody with such a mind as his. His technical understanding and knowledge of all things steam was second to none. I learnt so much from David when we first launched the P2 Dedicated Donations Scheme, getting to know all of the different components and whereabouts they were located on the engine, was a steep learning curve for me but David's patience in taking the time to explain things and point me in the right direction never faltered.



For several years Mark and I spent many a weekend in the company of David and other members of the Trust delivering the P2 Roadshows around the country. David's engineering knowledge was second to none and he commanded great respect from all those who had the pleasure of hearing him speak at the various events, he often had the room totally captivated. No engineering question put to David ever seemed to flummox him, he had an uncanny knack of being able to gear his response to his audience, from those highly qualified in the field to those not and if you didn't understand his explanation the first time round (as I often didn't), he had an amazing way of being able to deliver it to you in such a way, that even a complete novice like myself with little engineering knowledge at the time could understand and without making you feel

stupid. We also worked with David on many Railtours and at Heritage Railways and whenever he was present, he always took the time to talk to passengers and visitors alike and the respect and appreciation shown towards him was visible in abundance.

David will be greatly missed not only for his expert knowledge for all things steam including *Tornado* and *Prince of Wales* and the other projects he worked on but on a more personal level for his kindness, his dry sense of humour, his openness to call a spade a spade and just for being one of life's genuine Mr. Nice Guys, an absolute one of a kind and it has been a privilege knowing him.

We were deeply saddened to hear of David's passing and our thoughts are with Dominique and family at this time.

Gemma Maughan

I first met David through my employment with Rail Restorations where he was project managing the G5 build. He told me they were looking for someone to employ at the Trust and that he'd seen the way I worked and he needed someone as "fierce and organised" as me at DLW (and that was how I ended up at the Trust ... blame David!) following that I had the absolute pleasure of working with David at DLW for over five years and even after that we stayed in touch!



David was one of life's good guys and without a doubt one of the nicest people I have ever met. He was an absolute genius, and his knowledge will be missed throughout the heritage movement. He taught me a lot of things over the years and one which has always stuck in my mind is "nine little sips"! A trick his grandma taught him to get rid of the hiccups. David would always get me a glass of water, tell me to put my head down into glass and take nine little sips whilst holding my breath! Each and every time it worked.

The absolute highlight was organising a ginormous *Tornado* cake as part of 'Extreme Cake Makers'! David and I had to eat cake on camera, something we joked we "had prepared for the moment our whole life!". I never called David, "David", it was well known that my name for him was 'Ellipops' and I'm not sure to this day if he liked it or tolerated it!! In jest it was said that due to the amount of rework David had put into the poppet valve gear on No. 2007 that it should be renamed the "Ellippopet Valve Gear". I feel honoured to have worked alongside David and he will forever be missed!

Graham Morton - Like everyone else in the Trust and well beyond I was deeply saddened about David's passing. Perhaps a little cameo about the man illustrates his approach to life in general and engineering in particular. We used to meet in the gent's toilet at nearly every Convention, be assured this was the greatest of coincidences, honestly! We would have a wee natter as you do in such a situation, and I recall one particular time. I had been reading a superbly detailed book about the Austerity 2-8-0s and it kept referring to some gubbins called a 'clack valve'. I'm sure you're already ahead of me, by the time we got to hand drying I had been given a detailed but readily understandable idea about said valve, it's purpose and how it worked.

Daniela Filová

I met David around Christmas time in 2017. It was during the video interview for an engineering position at Darlington Locomotive Works. From the outset, his demeanour and intellect set him apart; his inquiries delved deeply into the realm of engineering, veering into the intricate world of steam locomotive construction. David's knowledge and genuine passion for steam locomotives and Railway heritage movement distinguished him as an invaluable figure within the industry. Upon my relocation to England, David's gracious guidance extended beyond engineering mentorship, introducing me to various peculiarities of English culture and heritage, almost as an adoptive father.

David's dedication to his profession resonated profoundly, evident in his tireless efforts as an engineer and his unwavering commitment to refining steam locomotive design and functionality. While his vast expertise in locomotive engineering was evident, David's interests extended to classical music, underscoring his diverse intellectual pursuits. Although his intense focus occasionally tested the patience of those around him, his genuine altruism and willingness to support others endeared him to those who took the time to truly know him. As a friend and mentor, David's unique blend of passion, intellect, and generosity left an indelible mark, making his absence an irreplaceable loss. **TCC**



David with Sir Nigel Gresley.

Daniela Filová

NOW AVAILABLE

SHOP NOW







NEW ARRIVALS

WWW.A1STEAM.COM/SHOP

Tornado Team DAY

We have a Tornado Team day on the 26th of October here at DLW for all of our under 18 supporters and their parents.

The day will be filled with STEM activities:

- Some cleaning of parts for the P2
- Visiting the Wagon Woods or
- The immersive experience at Hopetown.

The cost will be **£20** per TT member or **£30** for any siblings or friends who attend. This will include lunch for the young people.

Visit the Tornado Team page on our website to download further details or email: **tornadoteam@a1steam.com** or scan QR code.





David Elliott with the locomotive he did so much to bring to fruition, No. 2007 Prince of Wales.

RAILTOURS *Sophie Bunker-James*

The railtours team eagerly anticipate *Tornado's* first train after overhaul this autumn.

It has been extremely disappointing to miss the planned summer tours. We sometimes get asked why we advertise a train if there is a chance it won't run as planned. It takes over six months to establish and sell a train, and unfortunately the scale of engineering work has changed unexpectedly during that time, impacting the scheduled tours. As a charity, any cancellation comes as a big blow as it further delays our return to the earnings on which we rely, but more than that: we are heartbroken to let down our keen supporters and passengers who have put their faith in us.

The programme has changed shape a number of times as the AIs finish date has moved, however we are committed to running 'The Ribblehead Rambler' as the AI's first main line tour.

This is planned for Saturday 21st



Mike Brown

Ribblehead, Settle.

September, leaving from Leicester, East Midlands Parkway, Chesterfield, Doncaster and Leeds, heading across the iconic Settle and Carlisle Railway. Tickets are on sale now at:

a1steam.com/ribbleheadrambler or via the Booking Office on 01325

488215. It is sure to be a popular train so please consider booking before the rush when the locomotive steams.

Tornado will commit to a busy programme nationwide in 2025 and we hope that you travel with us soon.

TCC

LEGACY GIVING

Leave a Living Legacy

A further way in which you can help to keep No. 60163 *Tornado* on the main line or build No. 2007 *Prince of Wales* is by establishing a Legacy.

Instead of choosing to leave a legacy in their Will, many people prefer to make a large donation to causes close to their heart whilst they can enjoy seeing the impact that their generosity has made. Top Link provides a route for establishing these 'living legacies'. Unlike gifts in your Will, living legacies also allow us to claim gift aid, increasing the value of your donation by 25% at no additional cost to yourself. Furthermore, such donations to charity can reduce the total amount of inheritance tax due on your estate.

Leaving a Legacy in your Will

Leaving a legacy in your Will to the Trust can make a huge difference to our future.

There are three main types of gift you can leave in your Will:

- A residuary legacy: a part or the whole of your estate after all pecuniary legacies and specific bequests have been made, and after deducting any tax and expenses.
- A pecuniary legacy: a gift of a specific sum of money. This may devalue with inflation unless you ask your solicitor to index-link your gift.
- A specific bequest: a gift of specific items for example, property, land, art, or shares etc



Martin Birchall

Settle & Carlisle Railway.

Your donation can be hypothecated to an individual locomotive, or you may choose to donate to the A1 Steam Locomotive Trust as a whole. Large donations such as legacies and living legacies are not intended for the day to day running of the Trust, but help us to make larger purchases and investments to further the great work of the Trust. Leaving a legacy to the Trust not only helps to ensure that future generations can enjoy steam on the UK main line, but it may also reduce the rate of Inheritance Tax across your estate from 40% to 36%.

To register a legacy please email enquiries@a1steam.com, call 01325 460163 or visit www.a1steam.com for more information. TCC

NEW BUILD AI CLASS

No. 60163

TORNADO

100mph steam locomotive
star of Top Gear and Paddington 2

GET ON BOARD WITH TORNADO!

Since the locomotive first steamed in 2008, *Tornado* has delighted passengers nationwide, covering almost 150,000 miles! For a nostalgic steam train journey to remember, book your tickets to travel with this superstar of the rails at 21stcenturysteam.co.uk

Both the build and subsequent maintenance of *Tornado* has been funded by public donation. Most supporters donate the equivalent of a pint of beer a week to the project. Regular donations from just £10 a month help to secure the future of steam on the British main line railway. Support us at a1steam.com/donation

WWW.A1STEAM.COM

Follow us on

The A1 Steam Locomotive Trust, Darlington Locomotive Works, Bonomi Way, Darlington, DL3 0PY.

AI PROFILE – No. 60143 SIR WALTER SCOTT by Phil Champion

Darlington Works No. 2062 carrying boiler No. 3944 with tender No. 763 emerged in February 1949. Construction was nearly halfway through the class, it was one of two Darlington AIs and one from Doncaster to join the 20 already in traffic. Livery was apple green with black and white lining and old gold lettering and numerals. The owner's name was along the tender sides, 'BRITISH RAILWAYS'. It entered service from Gateshead (GHD) on 19th February 1949. It was on Grantham shed on 27th March then later that day was seen on a down van train at Norton South Junction. The first recorded passenger working was the 17:35hrs King's Cross–Newcastle of 6th March 1950. Next day, it was seen at Stockton at 11:30hrs double-heading the 19 coach Delaval–Holloway ECS with Class B1 No. 61258.



Jan McCabe

A colourised works' photo of No. 60143 at Doncaster

It was the 37th AI to be repainted in express passenger blue with black and white lining in September 1950 following its first general overhaul and boiler change at Doncaster (boiler No. 29800 fitted). The locomotive also left the works carrying a name, a naming that was nearly halfway through the class, after the eminent nineteenth century novelist, a number of AIs carrying names from characters in his novels. The new colour scheme lasted barely a year, going during a heavy intermediate repair at 'The Plant' in September the following year, one of the earlier AIs to be repainted in BR green with orange and black lining. Already six had been done and No. 60143 was one of four repainted that month. *Sir Walter Scott* was back on the Delaval–Holloway ECS, seen at Stockton on 2nd October with 18 coaches and one six-wheeler then on the 27th with Class B1 No. 61256 plus 19 coaches, a six-wheeler and three four-wheelers. Express passenger trains included a down York–Newcastle of 14th June 1951, one via the Durham coast into Newcastle on 11th November plus the up 'Flying Scotsman' from Newcastle on 16th June 1951 and the up one into Newcastle on 2nd August 1952. The

locomotive was in the capital on 22nd July 1953 as it departed King's Cross with the 14:00hrs King's Cross–Edinburgh train. No. 60143 revisited Doncaster for a further general overhaul during February 1953, leaving with boiler No. 29863, returning again throughout May 1954 for another one, this time leaving equipped with boiler No. 10595. A typical example of its work was the 13 coaches hauled on the Leeds to King's Cross train seen leaving Peterborough at 16:49hrs on 5th October 1954 but it once again called at 'The Plant' during October/November 1955 for another 'General' which included fitting boiler No. 29875. From 1954 to 1956 No. 60143 was seen on a number of named trains, the up 'Tees-Tyne Pullman', the up 'Heart of Midlothian' and 'North Briton' from Newcastle plus the up 'Flying Scotman' into and from Newcastle. *Sir Walter Scott* carried the later BR crest on its tender from 20th July 1957 following a very protracted overhaul at Doncaster lasting 155 days, the reason for which has not been recorded. In fact, No. 60143 seems to have been the AI that visited Doncaster most frequently for heavy repairs, re-appearing there in August 1958 (boiler No. 29862 fitted) and June

1959 (boiler No. 29847 fitted) for general overhauls.

A transfer to Heaton shed (52B) was made in June 1960. It passed Bishop Auckland when trains were diverted off the main line between Darlington and Durham with a King's Cross–Edinburgh passenger train on 28th October. *Sir Walter Scott* paid its final visit to Doncaster for a general overhaul during April and May 1961, leaving with its last boiler, No. 29850. It was in "immaculate" condition when photographed leaving Tweedmouth station on the RCTS 'Borders Rail Tour' of 9th July 1961, giving a good performance back to Newcastle reaching 80mph near Morpeth. Through much of the early 1960s No. 60143 was working north from Newcastle. In 1961 John Gilroy recorded these runs at Heaton two miles north of Newcastle Central, northbound passenger on 14th August, on the down 'Queen of Scots' on the 17th and Friday 25th taking over a northbound passenger at Central from Class A3 No. 60060 *The Tetrarch*. On Saturday 14th October he saw it with five other AIs at Heaton shed. At that shed it was coupled to Class V2 No. 60835 *The Green Howard* on Thursday 2nd November. Workings of note in 1962 were a down



Sir Walter Scott dips the troughs at Muskham.

goods at Newcastle on 24th March, the down CTAC excursion at Newcastle on 2nd June and the 09:04hrs Sunderland–Kings Cross ECS of 8th September which was terminated at York after which No. 60143 worked back to Newcastle.

Reallocation to Tweedmouth (52D) came on 9th September 1962 and a mix of work ensued. Mainline passenger work included bringing the 15:00hrs ex-King's Cross into Newcastle on the 10th, taking forward the Colchester–Glasgow train from Newcastle on 1st June 1963 and hauling the IN24 Edinburgh–Newcastle. The 2G85 Berwick–Newcastle stopping train plus its return was worked a number of times from October 1962 to April 1963. On 31st May 1963 *Sir Walter Scott* was sighted on the 3G38 Berwick–Newcastle parcels.

Along with four other AIs it was reallocated to York North (50A) on 8th September 1963. It reached Newcastle a lot as it was frequently seen being serviced on Gateshead shed. On 2nd December it brought the overnight sleeper into King's Cross, then on 1st February 1964 No. 60143 was on the 14:38hrs Newcastle–York and a photo from the 2nd shows it had lost its front numberplate. Non-passenger work was the 3B13 Newcastle–York parcels of 4th April, the 6S27 Tyne Yard–Millerhill of the 9th and the 7E70 Millerhill–Ollerton of

the 10th. On 13th April No. 60143 was back on the 2G85 Newcastle–Berwick stopper. On 15th April it brought a passenger train from Lincoln into Newcastle. Its final logged working was the 2G85 Newcastle–Berwick on 28th April. Withdrawal came on 6th May 1964. It was one of 10 sold to A. Draper of Hull for scrap. The last sighting was on 4th October on York shed where it had clearly remained out of use for some time. No. 60143 carried eight boilers, all to

diagram 118. Its service life of 15 years 2½ months was exactly the class average.

This history was compiled by Phil Champion based on the RCTS book "Locomotives of the LNER Part 2A", a database supplied by Tommy Knox of the Gresley Society, "The Glory and the Steam" by John Gilroy, "The Power of the AIs" by Gavin Morrison and various published photographs. Revised and updated by Graham Langer, July 2020. TCC



Nos. 60126 *Sir Vincent Raven* and 60143 awaiting scrap, 4th October 1964.

Bill Reed

Michael Denholm

Covenantors' Diary *by Jacqui Nicholson*

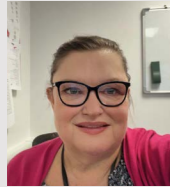

Here at the Locomotive Works we are eagerly watching the progress across the rails at North Road and the construction of Hopetown. The bridge joining us with this £35m project has just been installed.

This will allow the general public to view the Trust workshop from a gallery on the second floor of the building. Having access like this will boost our supporter numbers as people become aware of the P2 project here in Darlington, raising awareness of the Trust and its work.

Community is key for organisations like ours. Volunteers are our lifeblood, working in partnership and opening our door to rail enthusiasts builds our team, we even manage to convert some diesel fans. In January the A1 Trust had the honour of hosting the Darlington Railway Workers Coffee Morning at the Darlington Locomotive Works. They are looking for new members who have retired from the Railway Sector to join them for their monthly coffee mornings, the last Thursday of each month at 11:00hrs. Charles Tremeer spoke to them about the current new build and the improvements to the original design that will be made to *Prince of Wales*. They enjoyed being in the workshop environment and chatting with



Visitors to the Darlington Railway Workers Coffee Morning examine No. 2007.



Local school Gurney Pease Academy, have a tour of the workshop and P2 progress.

our volunteers over their joint passion in all things locomotive related. If you live close enough and are interested in joining, please get in touch with Alison - for more details by email hoptown@darlington.gov.uk

Building our supporter base is important at both ends of the age spectrum. In December we welcomed a party from a local school, Gurney Pease Academy, which runs a STEM Club whose members are currently renovating a semaphore signal. George Gorman gave the group a tour of the workshop, he was thrilled by their questions and their enthusiasm for learning about steam locomotives. Hopefully, some will become the Covenantors and Volunteers of the future alongside The Tornado Team members. Shelia will be sharing some exciting news soon with TT members of special events especially for them in 2024.

Covenantors are so important to the Trust, providing over 52% of the monthly income guaranteeing the continuity and stability of the Trust. These donations continue to keep *Tornado* on the main line where she belongs and ensuring that *Prince of Wales* will be completed and go on to operate on the national rail network alongside her. The investment of the Covenantors ensures that design innovations and modern technology improve the performance of the locomotives and keep them relevant and operational.

To thank you for being a Covenantor you will receive:

Prince of Wales

- Opportunity to buy ticket (seat already reserved) on one of the first trains hauled by No. 2007 *Prince of Wales*
- Reasonable access to No. 2007 at all times
- Print of the launch painting of *Prince of Wales* by Jonathan Clay
- Opportunity to join one of the teams building No. 2007
- Our quarterly magazine, *The Communication Cord*
- Monthly e-newsletter *The Mikado Messenger*
- Invitation to the annual convention and other exclusive events
- Covenantor card and opportunity to buy an exclusive tie.
- Your name inscribed on the Roll of Honour at Darlington Locomotive Works

Tornado

- A print of *Tornado*
- Access to view *Tornado* at all reasonable times
- Our quarterly magazine, *The Communication Cord*
- Monthly e-newsletter, *The Tornado Telegraph*
- Invitation to the annual convention and other exclusive events
- Special supporters' day with *Tornado*
- Covenantor card and opportunity to buy an exclusive tie.
- Your name inscribed on the Roll of Honour at Darlington Locomotive Works

If you wish to join or increase your current monthly donations please contact Janet either by email supporters@a1steam.com or call the office on (01325) 460163

If your eligibility for Gift Aid has changed, please contact us so we can update your records.

Thank you for your continued support of the A1 Steam Locomotive Trust. **TCC**

ARMED FORCES COVENANT

On the evening of Wednesday 12th June, The A1 Steam Locomotive Trust officially signed up to the Armed Forces Covenant. The signatories were AVM Randal Munro CB CBE TD VR DL, Brigadier Anna Kimber, Captain Will Blackett RN and, from the Trust, Steve Davies MBE. The Trust is proud to have signed this Covenant pledging our support and commitment to the Armed Forces community.



Pictured above, back row L-R: Janet Preshous (Supporter Administrator), Liz Gibson (Trustee), Jacqui Nicholson (Office Manager), Graham Langer (Trustee), Major General Celia Harvey OBE QVRM TD VR, Lt Randall Gyebi RN, Richard Courteney-Harris (Trustee), Cdr Victoria Percival MBE RN, Graeme Bunker-James (Commercial Manager), Lt Col Huw Parker (A1SLT Operations).

Front row: AVM Randal Munro CB CBE TD VR DL, Col Steve Davies MBE (Chairman), Brigadier Anna Kimber, Captain Will Blackett RN.

What is the Armed Forces Covenant?
The Armed Forces Covenant is a promise from the nation that those who serve or have served in the armed forces, and their families, are treated fairly.

It is a pledge that together we acknowledge and understand that those who serve or who have served in the armed forces, and their families, should be treated with fairness and respect in the communities, economy and society they serve with their lives. The Covenant supports serving personnel, service leavers, veterans, and their families, and is fulfilled by the different groups that have committed to making a difference. **TCC**



AVM Randal Munro and Col Steve Davies signing the agreement.



TENDER FRAMES DELIVERED TO DARLINGTON

In June, the new P2 class locomotive No. 2007 took another big step towards completion, as the tender frames which had been manufactured off site were delivered to the Darlington Works.

On 12th June, the tender frames for P2 No. 2007 *Prince of Wales* made the first leg of their journey to Darlington Locomotive Works (DLW). The completed frames were dispatched from Ian Howitt's* works in Wakefield for final gritblasting, preparation and painting in primer. This was undertaken at a specialist contractor to save mess and cost at DLW and the process was complete on 19th June.

The frames were delivered to DLW on Friday 21st June, signifying a major milestone achieved in the project to build the P2. Further fitting out will be required for pipework and conduits, with discussions around European Train Control Systems (ETCS) requirements ongoing. The tender tank (delivered in 2020) will be affixed to the frames as the tender takes shape. The tender wheel sets also require balancing but can be trial fitted before that occurs.

P2 Project Director and Trustee, Richard Courteney-Harris MBE, commented: "This is a significant milestone in *Prince of Wales*'s build and is testament to the continued efforts of everyone involved to bring it to fruition. We're absolutely delighted that we have another large piece of the P2 jigsaw back home and look forward to assembling the tender parts in due course. I hope supporters are hugely proud of what their faith in us has achieved."

Of the £450,000 required to finish the tender, so far over £250,000 has been spent, with around half of that being raised by the dedicated fundraising effort



Tender frames leaving Crofton.

of 'The Tender Club'. The remainder has been funded by regular P2 donations, which diverts spend away from other areas of the project and affects the rate of the build. With work still required to attach the tank to the frames, affix piping and electricals and balance the wheels, we still need your support.

The Trust invites anyone interested in the future of main line steam to join the club today to help No. 2007 *Prince of Wales* steam as soon as possible! More information can be found at a1steam.com/p2tender.

*We were saddened to hear of Ian Howitt's passing in July. (see below) **TCC**



Frames delivered to DLW in primer, and positioned in front of the tender tank and wheels.

Ian Howitt

Shortly after the delivery of the Tender frames from his Wakefield facility, the Trust was saddened to hear of the passing of Ian Howitt on 19th July.

Known to many as 'Hagrid', Graham Nicholas recalls the days nearly 20 years ago when Ian gradually became an integral part of the DLW team leading up to the completion of *Tornado*, armed with his 'attitude adjuster' (a metaphorical heavy lump of wood): "So much more than just the tender frames, his contribution at that time was extensive and invaluable ... if not exactly by the book, as delightfully captured in the *Absolutely Chuffed* BBC programme! I visited him at Crofton with David Elliott around 2006-ish whilst *Tornado*'s tender frames were under construction, supposedly to do an audit. Talk about a clash of worlds! I asked my questions, trying hard to keep a straight face as I got the predictable answers and listened politely to Ian's version of how a 'quality management system' was really meant to operate (the attitude adjuster featured prominently). To give him his due, the three or four pieces of paper I required duly appeared over the next few days. He was alright by me."

Ian's Crofton workshop was a hive of heritage engineering, working on both steam locomotives and traction engines.

Rob Morland reflects on time spent with Ian more recently: "He was straight talking and a wicked sense of humour. That is how I will always remember him."

Ian worked wonderfully in the engineering space with David Elliott, and it is sad indeed to lose them both within a short space of time. **TCC**

VOLUNTEERS by Jacqui Nicholson

The A1 Steam Locomotive Trust has a busy schedule planned for 2024. We are currently recruiting/re-activating volunteers.

There are a number of roles available, 'front of house' dealing with the public as well as engineering and support roles. Volunteering with the A1 Steam Locomotive Trust -All the tasks provide the opportunity to be part of the steam family and gain the enjoyment of being part of a busy team. For all sorts of reasons, a wide cross section of people (of all ages) find volunteering with the Trust not only satisfying, but very fulfilling, making new friends and expanding their social lives alongside the pleasure of a day's work well done.

Our volunteers are of all ages and backgrounds. Certain roles however such as steam support crew have a minimum age of 18 due to the safety critical nature of the roles. The Trust will offer you the opportunity to complete training to enable you to volunteer in different roles.

A willingness to smile and to help others do the same is the only other essential qualification

We are currently recruiting for the following roles:

MERCHANDISING LEAD (Volunteer)

The person taking on this role will be responsible for sourcing and purchasing merchandise for the Trust, ensuring that inventory levels are maintained and products are delivered on time to the Tours and Events. This position requires strong analytical skills, knowledge of the retail industry, and the ability to negotiate with suppliers. For a full job description or to apply for either of these roles please email enquiries@a1steam.com

RAIL TOUR STEWARDS AND MERCHANDISING SALES TEAM MEMBERS, ON-TRAIN VOLUNTEERS AND SUPPORT CREW.



Mandy Grant

Carriage Hosts are responsible for the safety of our passengers and provide information about who we are and what we do. The Support Team promote our merchandise and they also attend events with the Trust's goodies. The range of *Tornado* merchandise continually changes and includes books, badges, DVDs and mugs (which can be bought online via this website as well!). Our focus this year is to widen our geographical footprint.

DARLINGTON LOCOMOTIVE WORKS OPEN DAY STEWARDS

Our Works are open to the public on the first and third Saturday of each month between 10:00hrs to 15:00hrs. There are a variety of roles available as Trust stewards welcoming

visitors, offering refreshments, selling merchandise, giving insights into the work of the engineers and as Tour Guides explaining the history of our engines and the wider steam railway story, ensuring the safety and wellbeing of visitors.

If you are interested in any of these opportunities please take a minute to complete our survey by following the link. This is to gauge your availability, location and volunteering preferences. Use <https://ow.ly/vPeU50SM9vn> and a QR code too!! On receipt of your survey response, you will be issued with a Volunteer Agreement Form and a Medical Declaration Form (you may have completed these in the past but we need to confirm and update your record). You will also receive the Volunteer Handbook for your reference.

Lastly, I would like to take this opportunity to thank Charles Tremer for his commitment to the Volunteer Co-Ordinator role. He has stepped back from this but remains a steadfast volunteer at both Open Days and Onboard. Any enquires about volunteering please email volunteer@a1steam.com or call on the main office number and ask for Jacqui.

WAYNE KYTE

Wayne joined the Council of A1 Steam in January, replacing Paul Bruce who had stepped down from the council. Wayne will take a lead role on behalf of the Trust on People and Property matters.

Wayne is a career railwayman with a varied career in different parts of the UK. Starting his career in 1982 in a frontline role as a freight guard Wayne spent 10 years in a variety of training roles culminating in being the company Training & Development Manager. He moved into station and train management roles initially with Great Western Trains and then moved to GNER based in Newcastle in January 2002 with further roles following in Arriva Trains and Stagecoach Rail. During his 10 years with Stagecoach Wayne had a number of roles including Head of Stations, Route Manager and Service Development Manager. In the latter role he worked as part of Stagecoach's business development team bidding for new rail franchises including an extension to the East Midlands Trains franchise and the new Virgin Trains East Coast franchise.

In October 2018 Wayne took up a new challenge working in Saudi Arabia for RATP Dev. who are the third largest transport company in the world. In this role he was instrumental in setting up the new Riyadh Metro including recruiting and training staff, developing standards and procedures and overseeing the trial running for the new operation. Starting as Line Manager Wayne's most recent role was Director of Customer Service and Security with responsibility for a team numbering over 500 people. After more than 5 years based in Riyadh Wayne returned to the UK in December last year.

Wayne is a Chartered Member of the Chartered Institute of Personnel and Development and was recently recognised for completing 30 years as part of the professional people institute. He is looking forward to working with the board, council, staff and volunteers to build on the excellent work that the A1 Steam Trust has done for many years. **TCC**



P2 FUNDRAISING *by Sophie Bunker-James*

Launched this spring - The Valve Gear Club – final large component design and manufacture for the P2. Join The Valve Gear Club and help us manufacture and build David Elliott's final design for No. 2007, Prince of Wales.

The ultimate performance and economy of a steam locomotive is dependent on optimising the complete thermal system from the fire hole door to the top of the chimney. Assuming the boiler and smokebox are fundamentally sound, the most important areas for good design are the cylinders and valves. The design and manufacture of the unique cylinder monobloc, delivered to Darlington Locomotive Works in autumn 2023, was the first step towards building the powerhouse of the P2. With that work complete, we turn our attention to the other side of that same coin, the valve gear.

Lentz poppet valve gear is a more efficient design than Walschaerts valve gear, which is commonly found on UK locomotives, including *Tornado*. Lentz developed the concept by which an improved system of large passages, large areas through valves and suitably controlled valve events, would fully utilise the latent capacity of the boiler. Lentz poppet valve gear was fitted on the first P2, No. 2001 *Cock o' the North*, and we will be taking this principle and applying it to the valve gear design for No. 2007. By keeping true to the valve gear design of No. 2001 and adapting that design to incorporate post war developments, we are able to harness the potential efficiencies and additional power envisaged by Sir Nigel Gresley on *Prince of Wales*.

There were design issues with the Lentz rotary cam poppet valve gear that was installed on Gresley's original P2, *Cock o' the North* which at the time were not satisfactorily addressed and the locomotive was converted to Walschaerts valve gear. However, in the 1940s the Franklin Company in America took on the Lentz patents and they did what the Americans do best – develop and productionise a basic idea. Metal hardening methods developed through WW2 overcame the grooving problems in early continuous cams, and most components were "beefed up". Additionally, the cam slider mechanism changed from rack and pinion to screw operation resulting in less backlash which, more importantly, cannot back feed into the reverser.



We have been fortunate to obtain details of the Franklin developments and have incorporated these into the design of the valves and valve gear for No. 2007 (including copies of the original blueprints of Santa Fe No. 3752). Combined with modern design software and modelling, we have been able to bring the Lentz-Franklin valve gear into the 21st Century, specifically adapted for the new P2.

The arrangement of the valves around the three cylinders, with the middle cylinder raised, created an engineering dilemma which was never satisfactorily resolved – until now! Gresley's solution was to have inlet and exhaust valves on opposite sides inside cylinder. This resulted in very large and uneven clearance volume resulting in lost cylinder efficiency. The live and exhaust steam pipes sat next to each other, only separated by a steel wall, causing massive heat transfer – as much as 100°F recorded in tests at Vitry.

The alterations made in the Elliott design

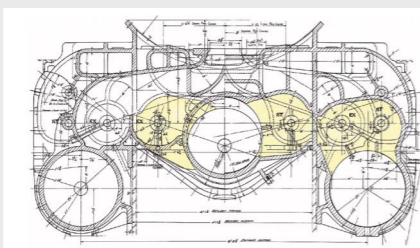

No. 2001 Clearance Volumes



David Elliott used 3D CAD to design many elements of the P2, a facility unavailable to the likes of Sir Nigel Gresley!

solve two significant weaknesses in the original P2 valve gear design:

1. The clearance volumes are now the same for each cylinder.
2. The live steam inlets are away from the exhaust steam pipes, reducing inefficiencies caused by significant heat transfer.

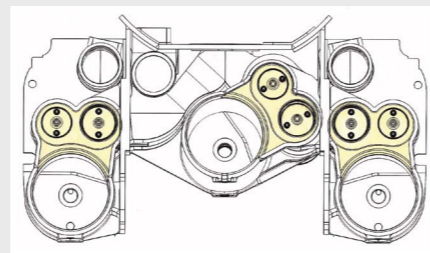

No. 2007 Solution - David Elliott's monobloc design deals with these issues most elegantly.

The design schematic for the valve gear is complete. Manufacturing drawings are now underway, and the next step is to produce a prototype and test rig to prove the design. The test rig will have loads applied and run for fatigue, replicating the forces anticipated when in use on the locomotive. Given the rapid application and removal, the use of hydraulic cylinders will replicate the load. Once proven, the prototype will be fitted to the locomotive for use on *Prince of Wales*, and the subsequent cam box will be manufactured. The test rig will be set up at Darlington Locomotive Works.

For manufacture and testing of the new design, we need to raise £300,000 - the first £50,000 of which will immediately go towards the building of a prototype and test rig. The Valve Gear Club seeks to raise these funds through donations of £1,000, in a lump sum or smaller instalments.

Thanks to the generosity of our supporters, after just one month we are within touching distance of reaching the £50k milestone. Make your donation today to help kick start progress on this crucial component!

Special benefits for members of The Valve Gear Club include:

- Exclusive Art Deco P2 Poster by Ed Laxton
- Priority to buy a ticket (seat already reserved) on one of the first trains hauled by No. 2007 *Prince of Wales*
- Reasonable access to No. 2007 at all times
- First choice of other components to sponsor
- Opportunity to attend 'The Valve Gear Club Day' when the prototype is tested.



Art Deco Poster by Ed Laxton

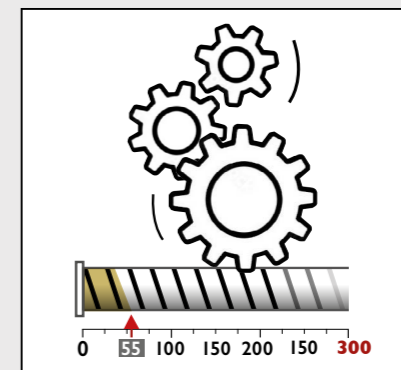

Valve Gear Club - 55 members.

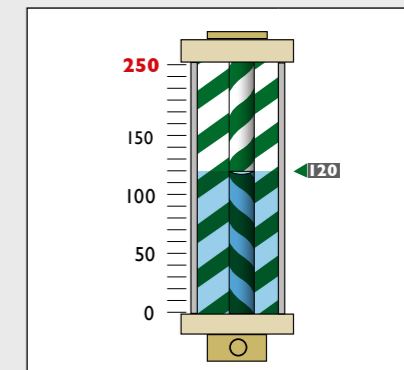

Tender Club Gauge - 120 members.

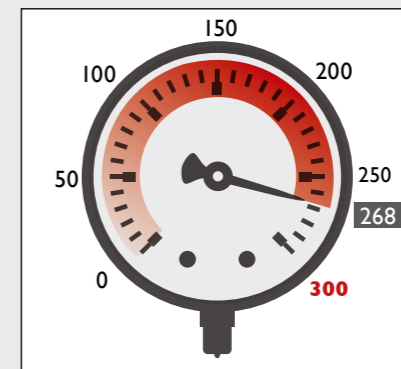

Boiler Club Gauge - 268 members.

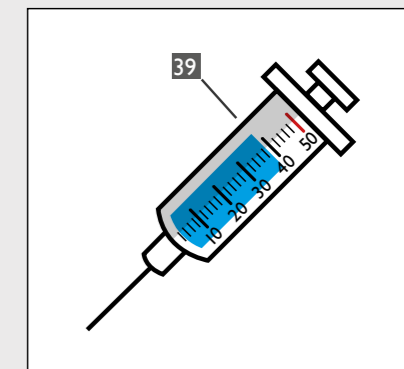

Injectors Club - 39 members.

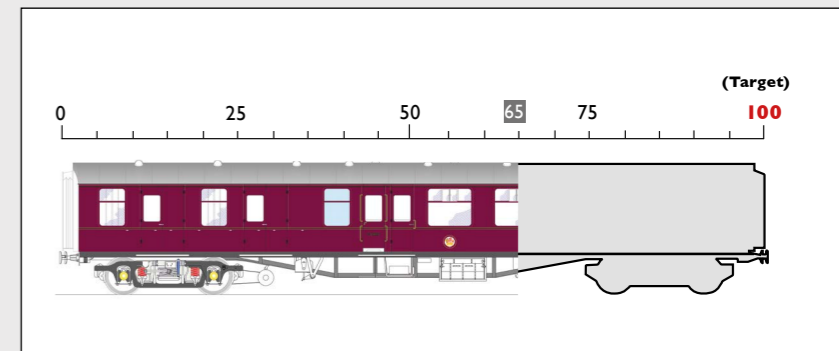

The P2 Coach Appeal - 65 supporters.

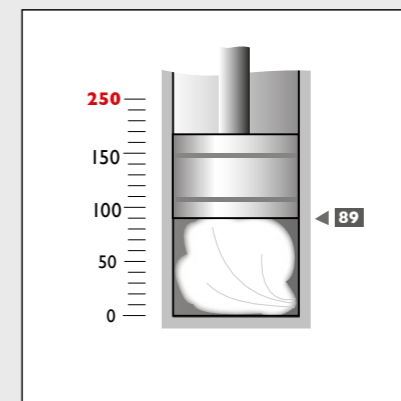

Monobloc Club - 89 members.

DLW Open Days - Open Days at the new site (Darlington Locomotive Works, Bonomi Way), have restarted on the first and third Saturdays of each month, 10:00hrs to 15:00hrs.

Covenantors - From as little as £10 per month, your regular donation makes a huge difference. If you haven't already done so, please consider joining us today and become a part of something special. Visit our website at <https://www.p2steam.com/support/regular-donations> for more information. **TCC**

P2 PROGRESS by Richard Courteney-Harris and Terry Graham

With the A1 overhaul now rapidly reaching its conclusion, our thoughts are now turning very firmly towards the P2 and planning for construction activity from now until the end of the current financial year (FY). We remain mindful that we're still 'overspent' on club accounts, in that we committed cash from reserves to pay for the monobloc, for example, before we had finished raising the money to pay for it. So, the theme for P2 construction planning in FY 24/25 will be "steady as she goes" to ensure we build at the pace we can afford.

We have looked at starting slowly, and then to increase the pace as, (hopefully), the cash reserves build again. We have budgeted for three major physical activities on the locomotive this year, and to begin a fourth should finances allow. These 'activities' will be planned for each financial quarter, and will run alongside the detailed design work and prototyping getting underway on the valve gear (see below).

The first is to finish the enabling activity, and then the top and tailing, to put the pony truck under the locomotive. The plan is that by the summer, with a fair wind, and no insurmountable problems, we should be looking at a 2-8-2. It won't be the entirely finished article as some detailed elements come later, but the bulk of the work will be done.

We will then move on to the monobloc and mounting it onto the frames. There can be no doubt that this a major piece of work; there is no template to follow and we will be dealing with very fine tolerances. We're aiming high and we hope that this will be complete in the Autumn of 2024.

At that point we should be able to switch our attention to work on the tender. The frames have been delivered and we now have the chance to plot the way forward. There will be some considerable

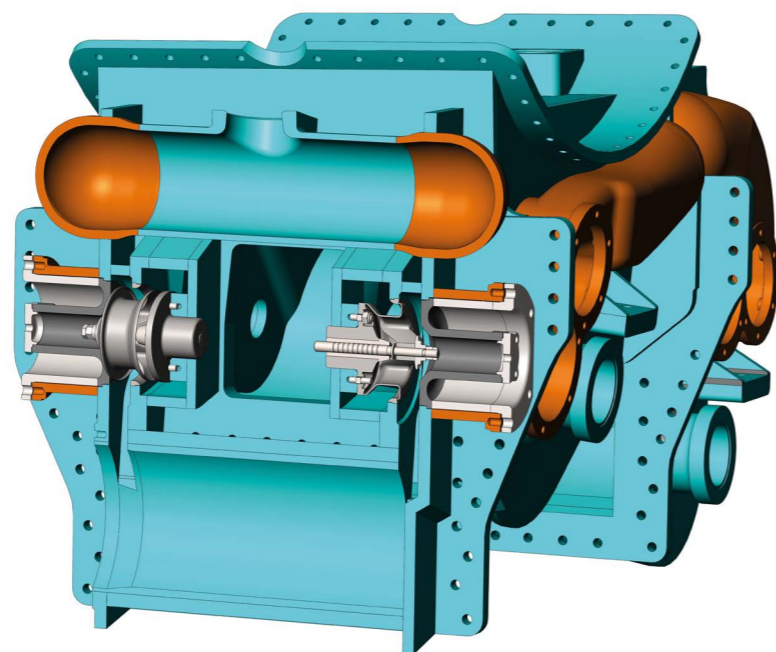

CAD of the cylinder assembly valve section.

work to fit the ETCS system and this will require careful planning. Of course, until the system has been properly evaluated on *Tornado*, we will have to manage our aspirations!

The final element of our 'quartet of progress' will be to start work on getting the boiler ready to put onto the frames. This will require a high degree of planning and a detailed budget to get underway. We're expecting delivery of the new P2 boiler imminently, but cost pressures and engineering priorities means that it will have to wait until the last part of the year.

There can be no doubt that this is a challenging schedule; it also depends on many interdependent activities and their successful completion. However, we're determined to push on as quickly as we're

able and accelerate progress within defined parameters and to budget.

Not content with this exciting programme, the intention is to start further work on the valve gear, as far as practicably alongside the four major activities already described. This means progressing and finishing the valve gear design work and building a first prototype.

We're aiming high here and there are many potential pitfalls along the way, but you should know that we're very much looking forward to getting on with the work at DLW and seeing further progress on the P2 in the coming year as the focus moves from external contractors to activity in our own facility.

TCC

VALVE GEAR REACHES FIRST MILESTONE

Over £50k raised in under two months, kick starting prototype production and reaches first milestone

The A1 Steam Locomotive Trust is building a brand new P2 class steam locomotive, and that project has taken another step towards completion thanks to the generosity of its donors. Just two months after its launch, the Valve Gear Club has raised over £50,000. Reaching this initial milestone enables work on manufacturing drawings to be finalised, and the production of a prototype and test rig to prove the technology, before it is fitted to the locomotive. This work is now scheduled to begin in August.

Reaching this first milestone so quickly is important as it allows this aspect of the build to gain momentum, however this is just the beginning as we will need to raise £250,000 more to complete the valve gear for all three cylinders.

P2 Project Director and Trustee, Richard Courteney-Harris MBE, said "I'm so very impressed and grateful for the way in which our wonderful supporters have generously leaned in to quickly raise over £50k in just two months. Their support means that we're much further ahead of the valve gear game than originally scheduled, moving this last major engineering and development area closer to completion."

The Gresley class P2 'Mikados' were the most powerful express passenger locomotives to operate in the UK. They were designed by Sir Nigel Gresley to haul 600-ton trains over the arduous Edinburgh to Aberdeen route. The ultimate performance and economy of a steam locomotive is dependent on optimising the complete thermal system from the fire hole door to the top of the chimney. Assuming the boiler and smoke box are fundamentally sound, the most important areas for good design are the cylinders and valves.

The design and manufacture of the unique cylinder monobloc, delivered to Darlington Locomotive Works in autumn 2023, was the first step towards building the powerhouse of the P2. With that work complete, our

attention has turned to the other side of that same coin: the valve gear. The P2 will be fitted with rotary cam, Lentz-Franklin poppet valve gear.

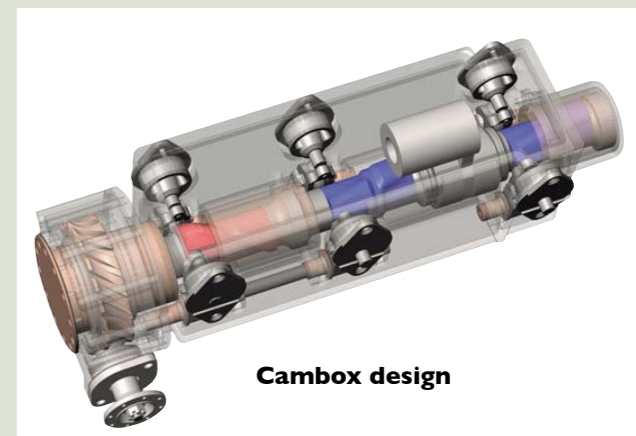

Cambox design

For manufacture and testing of the new valve gear design, the project needs to raise a total of £300,000. The Valve Gear Club seeks to raise these funds through donations of £1000, in a lump sum or smaller instalments. Full details can be found at a1steam.com/p2valvegear or scan QR code

We invite you to join the club today to help us build on this momentum and drive No. 2007 Prince of Wales to become Britain's most powerful steam locomotive! TCC



Attention all Club Members! - Exclusive badges are available to purchase -



The Boiler Club, The Mikado Club, The Cylinder Club, The Motion Club, The Tender Club
- All Club Badges £5.00 each (Badges shown actual size)

To purchase your badge please send a cheque for the relevant amount made payable to 'The P2 Steam Locomotive Company' and send to The A1 Steam Locomotive Trust, Darlington Locomotive Works, Hopetown Lane, Darlington DL3 6RQ.

THE A1 STEAM LOCOMOTIVE TRUST - CONVENTION 2024

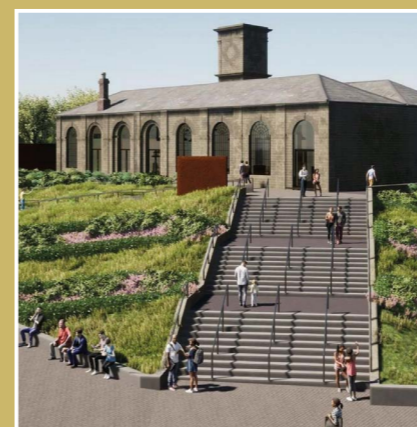

Hopetown Centre, Darlington.

SAVE THE DATE

**Saturday 12th
October 2024**

**Hopetown
Conference Centre
(Convention)**

**Hall Garth Hotel
(Dinner)**



Hall Garth Hotel, Darlington.

Invitations will be issued soon.

90th ANNIVERSARY OF THE GRESLEY P2 CLASS

The first locomotive of the Gresley P2 class, No. 2001 *Cock o' the North*, rolled out of Doncaster Works on 22nd May 1934. The P2s were the most powerful express passenger locomotives ever to run in Great Britain; their mechanical innovations were matched by their bold outward appearance. They were designed by Sir Nigel Gresley, principally to haul heavy express passenger traffic on the Edinburgh to Aberdeen main line which was noted for its steep gradients and tight curves. Although often described as a mixed success, the P2s were a bold step forward for British locomotive design.



Cock 'o the North at Doncaster in 1934 with Nigel Gresley and the design team.

In February 1933 the LNER authorised construction of two new locomotives for use on the Edinburgh to Aberdeen expresses. Subsequently known as the P2 class the order was later revised to just one locomotive. The frames were cut and laid in February 1934 with construction of the rest of the locomotive following quickly under Gresley's direction. On the 22nd May 1934 *Cock o' the North* rolled out of Doncaster works. The new locomotive was unlike anything seen before and was the first 2-8-2 express passenger locomotive to be built in the UK. Built with Lentz rotary cam poppet valves, a double chimney and Kylchap blast pipe, ACFI feed water heater and semi streamlined front end and cab. It was coupled to a standard design of tender as fitted to the LNER Pacifics. The tender however was the first to feature and all welded tender tank supplied by Metropolitan Vickers. The engine was also fitted with a Crosby chime whistle that had been presented to



No. 2007 Cock o' the North at Kings Cross Station, 1934



No. 2001 Taddy and Co. Cigarette Card Front.



No. 2001 Postcard Valentines.

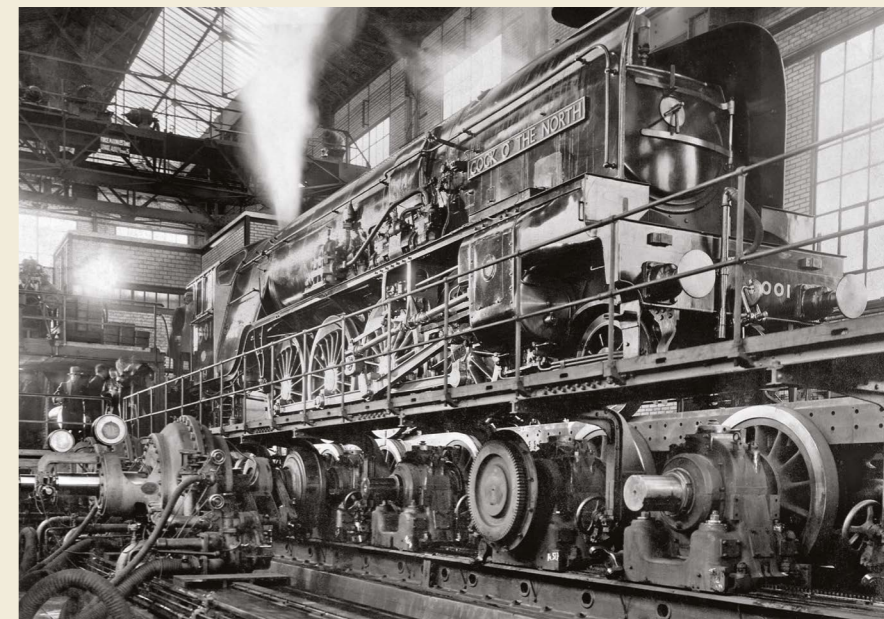

Cock o' the North on the test plant at Vitry.

Gresley some years before. The locomotive soon commenced running-in trials and the opportunity was taken to display the locomotive around the LNER railway system. The official press launch took place at King's Cross on the 1st June 1934 and in the following few days the locomotive was displayed at Ilford, Aberdeen and Edinburgh with people flocking to see the new locomotive.

With running in completed, the locomotive undertook test runs with the railways dynamometer car. On 19th June the engine took a test train of 19 carriages totalling 649 tons from King's Cross to Barkston and back. During the testing the results showed a maximum of 2,100 horsepower at the drawbar making it the most powerful express locomotive in Britain. The maximum speed obtained during the test was 76mph. On other tests higher speeds were attained with the locomotive reaching the mid 80s. With testing completed the locomotive was transferred to Haymarket shed on the 31st July 1934 and entered traffic over the route for which it was designed. The engine gained much local and national interest with many of the famous railway authors of the time traveling to see and ride on the locomotive. A brief trip to Doncaster was made in August 1934 for the fitting of tablet catching apparatus to make working the single line section of the route easier, with a return north to Scotland soon after.

Gresley had always been an advocate of a locomotive testing station in the UK and had built up a friendship with French

locomotive designer Andre Chapelon who had inspired some of the design for No. 2001. As soon as the locomotive was complete Gresley entered a dialogue with Chapelon about the possibility of testing No. 2001 on the stationary test plant that had recently opened in France, the LNER not having one of their own, and the only other in the UK not being capable of taking such a large locomotive. In November 1934 the engine was sent to Doncaster Works ready for preparation for its trip to the Vitry test plant near Paris. A few modifications were made, including the removal of the infinitely variable cams fitted to the locomotive as built due to frequent wear, and these were replaced by stepped cams giving only pre-determined positions of cut-off.

The locomotive left for France via the Harwich train ferry on the 4th December 1934 and arrived in Paris the following day. Testing commenced straight away with a Doncaster crew working the locomotive and Doncaster engineers observing the tests. Some problems were found with the axleboxes and these were modified in the Paris workshops and test continued. The opportunity was also taken to find the best blast pipe nozzle settings. The results obtained from the testing were as expected by the LNER engineers although not as good as the French pacific locomotives also undergoing test. The opportunity was also taken to test the locomotive on the French railway system, again with good results although at times maintaining steam pressure was a problem. The

French crew suggesting a larger firehole door and a bigger shovel would go some way to solving the problem. Prior to the engine returning to the UK the engine was cleaned up and placed on display at Paris Gare du Nord in company with a French pacific on the 17th February 1935.

On its return from France on the 21st February 1935 the locomotive once again returned to Haymarket shed and continued to work the Scottish expresses. On the 30th September 1937 the locomotive was withdrawn from traffic and sent to Doncaster for rebuilding as a streamlined locomotive as per the second batch of P2 locomotives. The engine also lost its Lentz valve gear and ACFI feed water heater in favour of the traditional Walschaerts valve gear and a traditional injector as they had proved uneconomical and expensive to maintain (American developments to Lentz valve gear happened too late to benefit the original P2).

No. 2001 returned to traffic on the 14th April 1938 and returned to Haymarket shed. *Cock O' The North* continued to put in good work in Scotland, returning to either Cowlairs or Doncaster work as required for attention. The only major work carried out being a new middle connecting rod and some minor boiler repairs during 1938. Although other members of the class suffered from broken crank axles and broken crank pins, No. 2001 seemed to escape from any of those problems, although it did suffer from overheating bearings like its sister engines.

With Gresley's death the new LNER CME Edward Thompson looked into trying to standardise the locomotive fleet and the P2 class were earmarked for rebuilding as Pacifics. The rebuilds were controversial and sparked much debate. The ungainly appearance was not popular with the staff and public alike and the locomotives rode badly prompting complaints from the crews. However, as Pacifics, the problems that had plagued the class disappeared, sacrificing power instead. No. 2001 was returned to Haymarket shed in September 1944. In August 1946 the locomotive was renumbered No. 501 and again in May 1948 to No. 60501 under the new British Railways numbering system. New problems started to appear on the class including the serious faults of cylinder blocks working loose. No. 60501 stayed in Scotland until 27th November 1949 when the locomotive was transferred to York. The locomotives were found to be unsuitable for work in Scotland as Pacifics and an attempt was

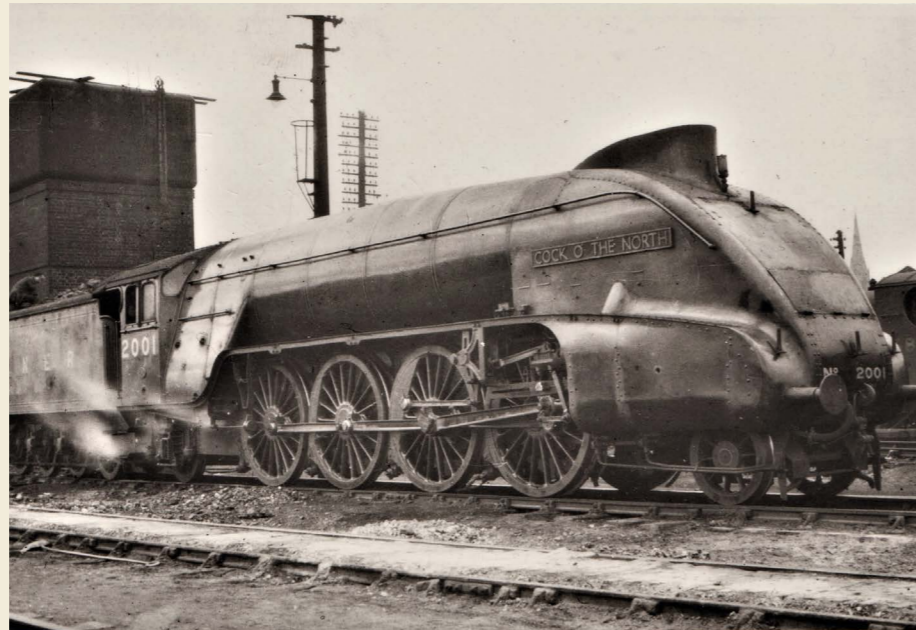

P2SLC Collection

Cock o' the North rebuilt with an A4 type front end and Walschaerts valve gear.

made to find more suitable work south of the border. Problems continued to plague the locomotives and No. 2001 was eventually withdrawn at Doncaster shed on 22nd January 1960 and cut up

the following month. Following its rebuild the locomotive had been into the works 26 times for repairs and overhauls. In its entire working life *Cock o' the North* completed almost 980,000 miles in traffic.

DESIGN ADAPTATIONS FOR No.2007

In much the same way that *Tornado* was constructed as the 50th A1 rather than a replica of the original members of the class, No. 2007 will be the 7th member of the P2 class, likewise allowing for improvements and variations in design. The decision to closely follow the pattern set by *Cock o' the North* means that the locomotive will have the original streamlining and rotary cam valve gear and will look, to all intents and purposes, like No. 2001. However, the Trust acknowledges that the original P2s has had certain weaknesses and No. 2007 will have these eliminated at the design stage. **TCC**

CAD model showing sources of design.

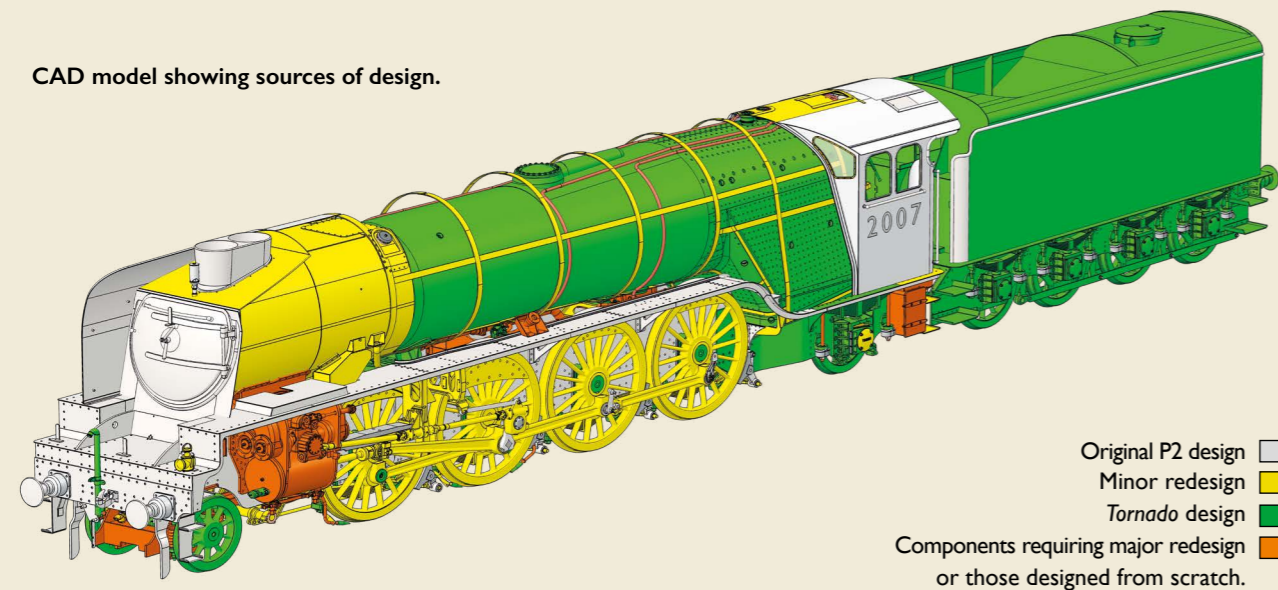

- Original P2 design
- Minor redesign
- Tornado design
- Components requiring major redesign or those designed from scratch

P2 DEDICATED DONATIONS UPDATE by Liz Gibson



Choosing a topic for the focus of this section is often easy but having exhausted my supply of seasonal puns last Spring I have had to come up with a different idea. At this time of year, a good deal of effort is going in behind the scenes getting ready for a busy season ahead, and putting the framework (you can see where this is going...) in place for all the events to come. Putting the framework in place for the P2 sets the foundation for the rest of the locomotive to grow around, and as I get more familiar with the list it's amazing to see just how many parts go to make up the basic structure. As hard as these parts are to see and as mundane as they may sound, they are all vital, and every one sponsored will nudge the project further towards completion.

- For £25 you can sponsor a 1" BSW driven bolt and nut
- A Buffer spring is £65
- The trailing frame stay fabrication is £800 while the forward frame plate machining and drilling can be sponsored for £1,200
- For anyone able to give rather more, the Pony Truck top centre casting is a little over £3,000!

As always, there are many more parts available and every part sponsored makes a wonderful and generous gift. If you're keener on process than function then how about narrowing things down by looking at a type of manufacturing method? Parts for the engine can be:

- Forged
- Welded
- Cast
- Laser cut
- Machined
- Rolled

...and all then expertly fitted together at the Works in Darlington. Now the new building is open for visitors, why not come along and see how all the wonderful contributions, sponsorship and donations come together to build an engine? Whatever the cost, size, placement or function, every sponsored item gets us one step closer to bringing this incredible locomotive to life. If you're interested in finding out more, please email Liz Gibson at:

dedicated.donations@a1steam.com and ask for more information about the parts available.

If you know of a business owner or company who may be interested in sponsoring an item on No. 2007 *Prince of Wales*, please contact **dedicated.donations@a1steam.com**. interested in sponsoring an item on No. 2007 *Prince of Wales*, please contact **dedicated.donations@a1steam.com**.

TCC

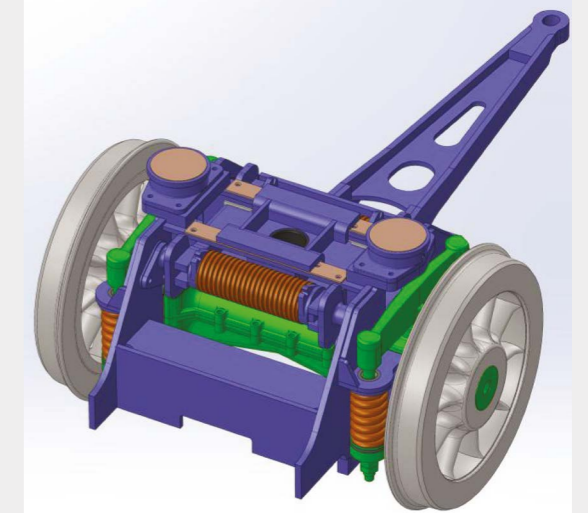

CAD of Pony Truck.

•WORKSHOP NOTES.



Keith Wood found this previously unknown image of No. 2001 *Cock o' the North* at work. Interestingly the nameplate seems to have been re-touched.



Ian Gibson, our dynamic cleaner, proudly displays our 'Loo of the Year' awards.

ARMY ON TRACK AT DLW

In the first weekend in June, 507 STRE (Railway Infrastructure) Royal Engineers returned to Darlington Locomotive Works (DLW) to continue their track laying training, and assist the A1 Steam Locomotive Trust putting tracks in place around the new Works site. 507 Specialist Team Royal Engineers (STRE) are an Army Reserve unit that specialises in the repair and construction of railway infrastructure. They recruit from the railway industry and are based in Nottingham.

During the weekend's impressive efforts, over 110m of plain line was laid, and a vital set of points positioned, leading off site to connect with the main line.

The Army is due to come back to DLW to lay much more track on an extended exercise this autumn.



507 STRE installing a Cv9.25 turnout in early June.



Plain line installation, on a hot Saturday afternoon.



507 STRE laying out concrete sleepers in advance of main works.

In November, it is planned that 26 Field Squadron of 32 Engineer Regiment will spend a number of weeks on site, with the intention of laying all remaining plain line track (around 750m, completing the stretch from DLW to the main line). Before then, we must raise funds to secure the 4000 additional tons of ballast required, or this opportunity will be lost. The ballast would ideally be laid in September, well ahead of the track laying, as good weather allows. Our team of volunteers are poised to lay the ballast but can't do this without your donations.

We ask that you consider sponsoring a 28tonne wagon load for £630, and join phase two of the P-Way Gang. Thank you all for your interest and support as we make the new Works work for our locomotives. **TCC**

Almost 50 people have now sponsored a wagon load, but you can also donate by the ton from just £22.50.

Sign up at: a1steam.com/pwayballast or scan QR code.



Work continues on the turnout between Otley Terrace and DLW.

PRIME MINISTER RISHI SUNAK VISITS DLW

On April 2nd, we were pleased to welcome the then Prime Minister, The Rt Hon Rishi Sunak, and our local MP at the time, Peter Gibson, to Darlington Locomotive Works. The visit enabled the PM to hear an update on A1 No. 60163 *Tornado*, P2 No. 2007 *Prince of Wales* and see the continuing works on the new mainline connection so the locomotives can regularly return 'home'. Our chairman Steve Davies also briefed on future plans including a turntable at the site, the 200th Anniversary of the Stockton and



PM Sunak taking a closer look at the P2 Motion.



The whole DLW team of staff and volunteers stand with MP Peter Gibson and PM Rishi Sunak.

Darlington Railway and more. This was the first visit of any Prime Minister to the Trust, and we are always open to discussing our

objectives with any organisation, in or out of government, that might support those aims. **TCC**

THE P-WAY GANG – PHASE TWO

The move into our new home at DLW has had a transformational impact on our ability to deliver the Trust's objectives, with a corresponding improvement in the quality of the working environment we offer our staff. P2 *Prince of Wales* is now set fair for completion in this new state-of-the-art workshop, and our facility will also offer a dedicated 'home base' for *Tornado* in between its mainline forays, the latter for the first time. And, of course, once the P2 is completed the V4 will be constructed within the new Works. But one of the key objectives of the move, that of achieving connectivity with the main line and within the railway heritage site being developed at Darlington, is still to be completed. It is recognised that the constant movement of large steam locomotives on the back of road vehicles is not conducive to their health given the unnatural stresses placed on the frames from the loading and unloading process and that's why we view the track infrastructure we have committed to as being as important for the engines as is the normal maintenance regime. The mainline connection directly onto the Bishop Auckland branch, on the route of the original 1825 Stockton and Darlington Railway, will fulfil this need and also allow DLW to be able to offer servicing facilities for other locomotives visiting the area.

Our plan for the delivery of this infrastructure is well advanced, including the acquisition and stockpiling of rails, sleepers, and track fittings, but we have a need for considerable amounts of ballast. The Army has very kindly been involved in the initial tracklaying project and returned in May, but for this visit to be productive we need to have brought in circa 2,000

tonnes of ballast, the total amount required for the whole project being 6,000 tonnes. We have managed to agree an exceptional deal of £22.50 per tonne including transport from a quarry in Leyburn, and for those with knowledge of the aggregates sector, you will identify that this is indeed a fantastic price. It will be delivered in 28 tonne loads, at a cost of £630 per load. Our requirement is for 6,000 tons, which will allow for all of the plain line to be laid.

In June, we launched our P-Way Gang Ballast Appeal, Phase Two of the 'P-Way Gang'. As a valued supporter, we ask that you consider sponsoring one or more loads at £630 per go. The ball has already been set rolling with generous contributions meaning we have already secured funding for over 200 tonnes of ballast, so well on our way, and we would of course recognise your contribution to this important project.

The main incentive for completing this undertaking is to help maintain our engines in excellent condition by significantly reducing the number of occasions we have to use road transport and is an essential component in delivering our vision for the Trust. We hope that you will support us in this endeavour.

Find out more and donate to Phase Two at www.a1steam.com/pwayballast **TCC**



VOLUNTEERS ON POINT AT DLW by Terry Graham

Following the autumn '23 visit of STRE 507, a hardy team of volunteers have been working tirelessly to advance progress on the trackwork around the new site.

In Spring, the team ballasted the track laid by STRE 507 Regiment to the right height and the curve was corrected. Initially, the ballast was only packed on every 5th sleeper from the pad, with more to do going into the summer. Sleepers were fitted under the rails, now at the correct height from the pit road but not all yet packed with ballast. During the shorter, colder days it can feel like a thankless task and a lot of manual work has been put in to get this far.

The fence next to the track has been installed by an NR contractor and is finished up to the 1861 shed.

Following the return of 507 STRE this June, the volunteers from the AISLT and DRPS have made progress in the following areas:

- Working on the turnout south of Otley Terrace bridge.
- Levelling ballast for the plain line north of the 1861 shed.
- Removing chairs from over 350 wooden sleepers recovered from the carriage works site.
- Levelling ballast North of Otley Terrace bridge so we can unload one of the turnouts from Darlington into its final position

In July, work progressed on the network connection turnout at the north end of the site. Volunteers from AI and DRPS completed the following work.

- Gauge corrections to the switch panels, involving removing baseplates, plugging and redrilling bearers before refitting baseplates
- Installation of the crossing (previously only laid in place by STRE 507)
- Re-space and square off circa 30 timber bearers

Whilst the Army is due to return in November to lay the plain line, it is our team of Volunteers who will put in the hard graft, laying the ballast in early autumn in preparation. Our volunteers will also be focused on installing the turn outs around the site. Their hard work and dedication are already paying dividends with visible progress being made week on week.

Thanks to James, Richard, Chris, Terry all the volunteers from AISLT and DRPS for their ongoing efforts.

Our new P-Way Gang Ballast Appeal provides the materials for our volunteers to push forwards. We have also had confirmation two sets of points being decommissioned from Darlington Up Sidings have been recovered and transported across town to be upcycled and reused on the DLW site, north of Otley Terrace bridge. We are very lucky to be able to secure approval for the release of track material in such good condition. **TCC**

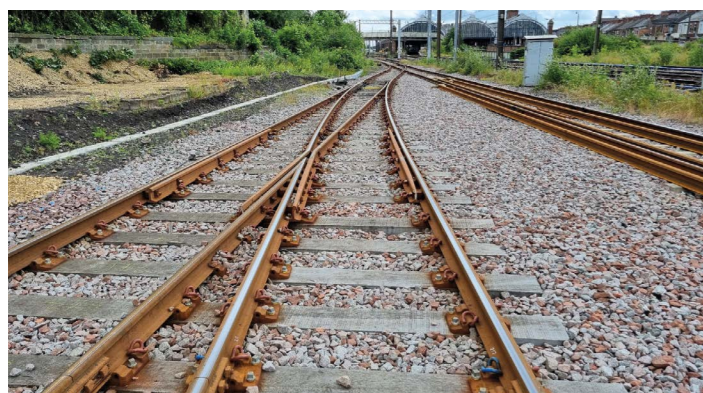

One of the turnouts removed from Darlington Up Sidings.



Fitting a Pandrol clip to a fishplate.



One of the new turnouts taking shape.



Tightening fishbolts.

FROM THE ARCHIVES by Graham Langer

Winter 2004 – Progress centred on the *Tornado's* boiler; a decision had been taken to go with coal firing, increases in the cost of oil meant that this option was no longer viable and so the design contract, which had been awarded to DB Meiningen specified a coal-fired grate. At Darlington work had concentrated on setting up the fully machined valve gear and assembling the reverser and its mechanism. Having been reduced in height to Railtrack's new loading gauge limit, the cab had been assembled and riveted at the North Yorkshire Moors Railway and returned to DLW for fitting.

Winter 2009 - On Thursday 19th February 2009 *Tornado* was officially named by TRH The Prince of Wales and The Duchess of Cornwall at York Station. Their Royal Highnesses arrived by the Royal Train and were greeted by civic dignitaries and members of The AI Steam Locomotive Trust. Having met a representative number of covenantors, volunteers and contractors as *Tornado* backed

down onto the train they proceeded to the podium to officially name the locomotive. Prince Charles paid tribute to all those who brought the dream to reality and then removed the banner covering the nameplate; moments later an RAF flypast of a Tornado F2 and two Hawk jets thundered over the station. After meeting the crew The Prince joined them on the footplate while The Duchess accompanied Dorothy Mather and other guests to the train. *Tornado* then departed with the Royal Train for Leeds with the Prince still on the footplate. It was an extraordinary start to what was become an extraordinary career.

Winter 2014 – Coincidentally *Tornado* had moved from the Nene Valley Railway to Barrow Hill Roundhouse for winter maintenance which included a 'C' exam. The safety valves and injectors were removed from the locomotive for annual inspection and maintenance again and the copper pipework which feeds steam from the various control valves

in the cab was removed and taken to Darlington Locomotive Works for annealing to ensure that the pipework retains its flexibility. After a programme of planned stay replacement by staff from Meiningen the locomotive passed a successful boiler test on 11th February, ready to resume its mainline career.

Winter 2019 – *Tornado* emerged from a protracted and complicated period of winter maintenance and West Coast Railways stepped in when DB Cargo were unable to move the locomotive to the Wensleydale Railway for running-in, heralding their involvement in running 'The Aberdonian' series which DB(C) were struggling to resource. Despite calls on his time to help with *Tornado*, David Elliott managed to push on with engineering on No. 2007 *Prince of Wales* and although the locomotive had to be partially dismantled to allow further work, progress in making and fitting a myriad of parts continued apace.

TCC



The then Prince of Wales meets the locomotive crew after the naming ceremony.

The A1 Steam Locomotive Trust is pleased to display the logos of organisations giving us their ongoing support. Their contribution is gratefully acknowledged.

WILLIAM COOK CAST PRODUCTS

PRINCIPAL SPONSOR



York EMC Services



M. H. SPENCER LIMITED



The Gresley Society Trust



I.D.HOWITT LTD

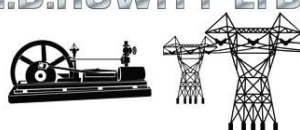

THE A1 STEAM LOCOMOTIVE TRUST CONTACTS

President **David Champion** (david.champion@a1steam.com)

Vice Presidents **Ben Godfrey** (ben.godfrey@a1steam.com),

Rick Peacock-Edwards (rick.peacock-edwards@a1steam.com)

Board of Trustees

Steve Davies Chairman (steve.davies@a1steam.com)

Richard Courteney-Harris P2 Project Coordinator (richard.courteney-harris@a1steam.com)

Liz Gibson Events and Volunteers (liz.gibson@a1steam.com)

Wayne Kyte Property Supervisor (wayne.kyte@a1steam.com)

Graham Langer Publications (graham.langer@a1steam.com)

Ben McDonald Group Engineering Director (ben.mcdonald@a1steam.com)

Huw Parker Operations Director (huw.parker@a1steam.com)

Chris Walker Finance (chris.walker@a1steam.com)

Advisers to the Board

Tom Benson Review Coordinator

Graeme Bunker-James Commercial Manager (graeme.bunker-james@a1steam.com)

Terry Graham P2 Project Manager (terry.graham@a1steam.com)

Andy Hardy Archivist

Gary Hughes Council & Board Business Coordinator (gary.hughes@a1steam.com)

Rob Morland Electrical (rob.morland@a1steam.com)

Graham Morton Finance (graham.morton@a1steam.com)

Graham Nicholas Professional Head of Engineering (graham.nicholas@a1steam.com)

Richard Peck Commercial (richard.peck@a1steam.com)

Charles Tremeer Volunteer Coordinator (charles.tremeer@a1steam.com)

Engineering

Alan Parkin Electrical Design (alan.parkin@a1steam.com)

Administration

Sophie Bunker-James Marketing and Communications Director (sophie.bunker-james@a1steam.com)

Jacqui Nicholson Office Manager (jacqui.nicholson@a1steam.com)

Janet Preshous Data Administrator (janet.preshous@a1steam.com)

Editor

Graham Langer (graham.langer@a1steam.com)

Picture Editor

Situation vacant

Design

Kevin Lumb (kevin@limegroveprintanddesign.co.uk)

* All information correct at the time of going to press early August 2024. For up-to-date information and dates please check the website www.a1steam.com.

- The A1 Steam Locomotive Trust, Darlington Locomotive Works, 9 Bonomi Way, Darlington DL3 0PY
- e-mail: enquiries@a1steam.com ● website: www.a1steam.com ● tel: 01325 460163

Darlington Locomotive Works is normally open to the public on the first and third Saturday each month (10am – 3pm).

Access to the works is in association with Head of Steam: Darlington Railway Museum where Covenants are entitled to free entry (with Covenantor card). Charity registration No. 1022834.

The Trust respectfully requests that anyone wanting to see *Tornado's* main line passenger trains follows the rules of the railway and only goes where permitted.

© 2024 The A1 Steam Locomotive Trust except where shown. Views of contributors are not necessarily those of The A1 Steam Locomotive Trust.